

*Changes for the Better*

 **MITSUBISHI**  
PROGRAMMABLE CONTROLLERS  
MELSEC-F

## USER'S MANUAL

FX-1PG/FX<sub>2N</sub>-1PG PULSE GENERATOR UNIT

**FX**



## Foreword

- This manual contains text, diagrams and explanations which will guide the reader in the correct installation and operation of the FX-1PG/FX2N-1PG pulse generator unit. It should be read and understood before attempting to install or use the unit.
- Further information can be found in the FX PROGRAMMING MANUAL(II), FX/FX2N series hardware manuals.
- If in doubt at any stage of the installation of FX-1PG/FX2N-1PG pulse generator unit always consult a professional electrical engineer who is qualified and trained to the local and national standards that applies to the installation site.
- If in doubt about the operation or use of FX-1PG/FX2N-1PG pulse generator unit please consult the nearest Mitsubishi Electric distributor.
- This manual is subject to change without notice.



# FX-1PG/FX2N-1PG PULSE GENERATOR UNIT

## USER'S MANUAL

Manual number : JY992D65301

Manual revision : E

Date : April 2003

## **Guidelines for the Safety of the User and Protection of the FX-1PG/FX2N-1PG pulse generator unit.**

This manual provides information for the use of the FX-1PG/FX2N-1PG pulse generator unit.. The manual has been written to be used by trained and competent personnel. The definition of such a person or persons is as follows:

- a) Any engineer who is responsible for the planning, design and construction of automatic equipment using the product associated with this manual, should be of a competent nature, trained and qualified to the local and national standards required to fulfill that role. These engineers should be fully aware of all aspects of safety with regards to automated equipment.
- b) Any commissioning or service engineer must be of a competent nature, trained and qualified to the local and national standards required to fulfill that job. These engineers should also be trained in the use and maintenance of the completed product. This includes being completely familiar with all associated documentation for said product. All maintenance should be carried out in accordance with established safety practices.
- c) All operators of the completed equipment (see Note) should be trained to use this product in a safe manner in compliance to established safety practices. The operators should also be familiar with documentation which is associated with the actual operation of the completed equipment.

**Note :** The term ‘completed equipment’ refers to a third party constructed device which contains or uses the product associated with this manual.

## Notes on the Symbols Used in this Manual

At various times throughout this manual certain symbols will be used to highlight points which are intended to ensure the users personal safety and protect the integrity of equipment. Whenever any of the following symbols are encountered its associated note must be read and understood. Each of the symbols used will now be listed with a brief description of its meaning.

### Hardware Warnings



1) Indicates that the identified danger **WILL** cause physical and property damage.



2) Indicates that the identified danger could **POSSIBLY** cause physical and property damage.



3) Indicates a point of further interest or further explanation.

### Software Warnings



4) Indicates special care must be taken when using this element of software.



5) Indicates a special point which the user of the associate software element should be aware.



6) Indicates a point of interest or further explanation.

## CONTENTS

|  |      |
|--|------|
| 1. INTRODUCTION . . . . .  | 1-1  |
| 1.1 Introduction . . . . .   | 1-1  |
| 2. OUTSIDE DIMENSIONS . . . . .  | 2-1  |
| 2.1 Outside Dimensions . . . . .                                       | 2-1  |
| 3. TERMINAL ARRANGEMENT . . . . .                                      | 3-1  |
| 3.1 Terminal Arrangement and LED Indication . . . . .                  | 3-1  |
| 4. SPECIFICATIONS . . . . .  | 4-1  |
| 4.1 Specifications . . . . .   | 4-1  |
| 5. BFM LIST . . . . .  | 5-1  |
| 5.1 BFM List . . . . .   | 5-1  |
| 5.2 System of Units and Parameter Setting . . . . .                    | 5-3  |
| 5.3 Speed Data and Position Data . . . . .                             | 5-6  |
| 5.4 Position Data, Home Position and Current Position . . . . .        | 5-9  |
| 5.5 Operation Command . . . . .  | 5-10 |
| 5.6 Status and Error Codes . . . . .                                   | 5-13 |
| 6. OUTLINE OF OPERATION MODES . . . . .                                | 6-1  |
| 6.1 JOG Operation and Machine Home Position Return Operation . . . . . | 6-1  |
| 6.1.1 DOG Switch . . . . .   | 6-2  |
| 6.1.2 Overshoot Detection Home Return Positioning Method . . . . .     | 6-3  |
| 6.1.3 Undershoot Detection Home Return Positioning Method . . . . .    | 6-4  |
| 6.1.4 Home Position Return Operation . . . . .                         | 6-5  |

|      |   |      |
|------|---|------|
| 6.2  | Single-Speed Positioning Operation and Interrupt Single-Speed Positioning Operation . . . . . | 6-6  |
| 6.3  | Two-Speed Positioning Operation and External Command Positioning Operation . . . . .          | 6-7  |
| 6.4  | Variable Speed Operation . . . . .  | 6-8  |
| 6.5  | Common Matter for Operation Modes . . . . .   | 6-9  |
| 6.6  | Connection of DOG and STOP Inputs and Handling of Limit Switches for Limit Detection .        | 6-10 |
| 6.7  | Various Operation Modes and Buffer Memory Setting . . . . .                                   | 6-12 |
| 7.   | OUTLINE OF FROM/TO INSTRUCTION (PC) . . . . .   | 7-1  |
| 7.1  | FROM/TO Instruction . . . . .   | 7-1  |
| 8.   | I/O SPECIFICATIONS . . . . .  | 8-1  |
| 8.1  | I/O Specifications . . . . .  | 8-1  |
| 9.   | EXTERNAL CONNECTION EXAMPLES . . . . .  | 9-1  |
| 9.1  | Example of Connection Between FX-1PG and Stepper Motor . . . . .                              | 9-1  |
| 9.2  | Example of Connection Between FX <sub>2N</sub> -1PG and Stepper Motor . . . . .               | 9-3  |
| 9.3  | Example of External Connection (MR-C Servo Amplifier) . . . . .                               | 9-5  |
| 9.4  | Example of External Connection (MR-J Servo Amplifier) . . . . .                               | 9-7  |
| 9.5  | Example of External Connection (MR-J2 Servo Amplifier) . . . . .                              | 9-9  |
| 9.6  | Example of External Connection (MR-H Servo Amplifier) . . . . .                               | 9-11 |
| 10.  | PROGRAM EXAMPLES . . . . .  | 10-1 |
| 10.1 | The reciprocation by single-speed positioning . . . . .                                       | 10-1 |
| 11.  | DIAGNOSTICS . . . . .   | 11-1 |
| 11.1 | Preliminary Checks and Error Indication . . . . .   | 11-1 |

# MEMO



## 1. INTRODUCTION

### 1.1 Introduction

- The FX-1PG/FX<sub>2N</sub>-1PG pulse generator unit (hereinafter referred to as “PGU”) performs simple positioning of an independent axis (not interpolation control between multiple axes) by supplying a prescribed quantity of pulses (100 kHz maximum) to drive amplifiers for servo or stepper motors.
- The FX-1PG is attached as an extension to the FX/FX<sub>2C</sub> series programmable controller (hereinafter referred to as “PC”), and the FX<sub>2N</sub>-1PG is attached as an extension to the FX<sub>2N</sub> series PC. Each PGU functions as a special block which transfers data with the PC using the FROM/TO instructions, and occupies 8 points of inputs or outputs. Up to 8 PGU units can be connected to single PC so operation for independent 8 axes can be realized.
- The PGU provides connection terminals for positioning operations that require high-velocity responses as well as those used for pulse train outputs. Other general I/O operations are controlled via the PC.
- Because all the program for positioning control are executed in the PC, the PGU does not require dedicated teaching panel, etc. As the programming tools for the PC, the following devices are available without modification.
  - ① FX-10P-E and FX-20P-E
  - ② General-purpose personal computer (IBM)
- Various data access units as follows can be connected to the PC to set or display the positioning data.
  - ① FX-10DU-E and FX-20DU-E
  - ② FX-25DU-E, FX-30DU-E, FX-40DU-ES, FX-40DU-TK-ES and FX-50DU-TK(S)-E

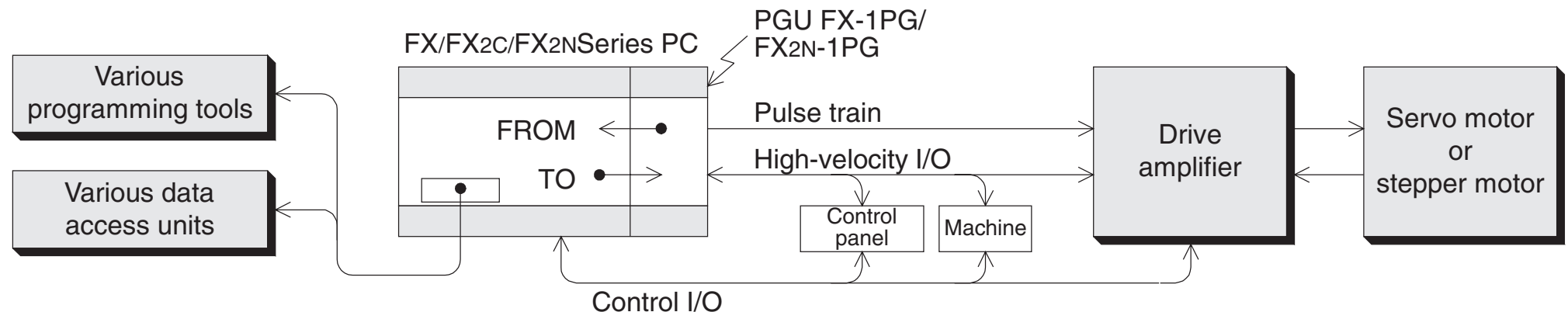

## 2. OUTSIDE DIMENSIONS

### 2.1 Outside Dimensions

FX-1PG

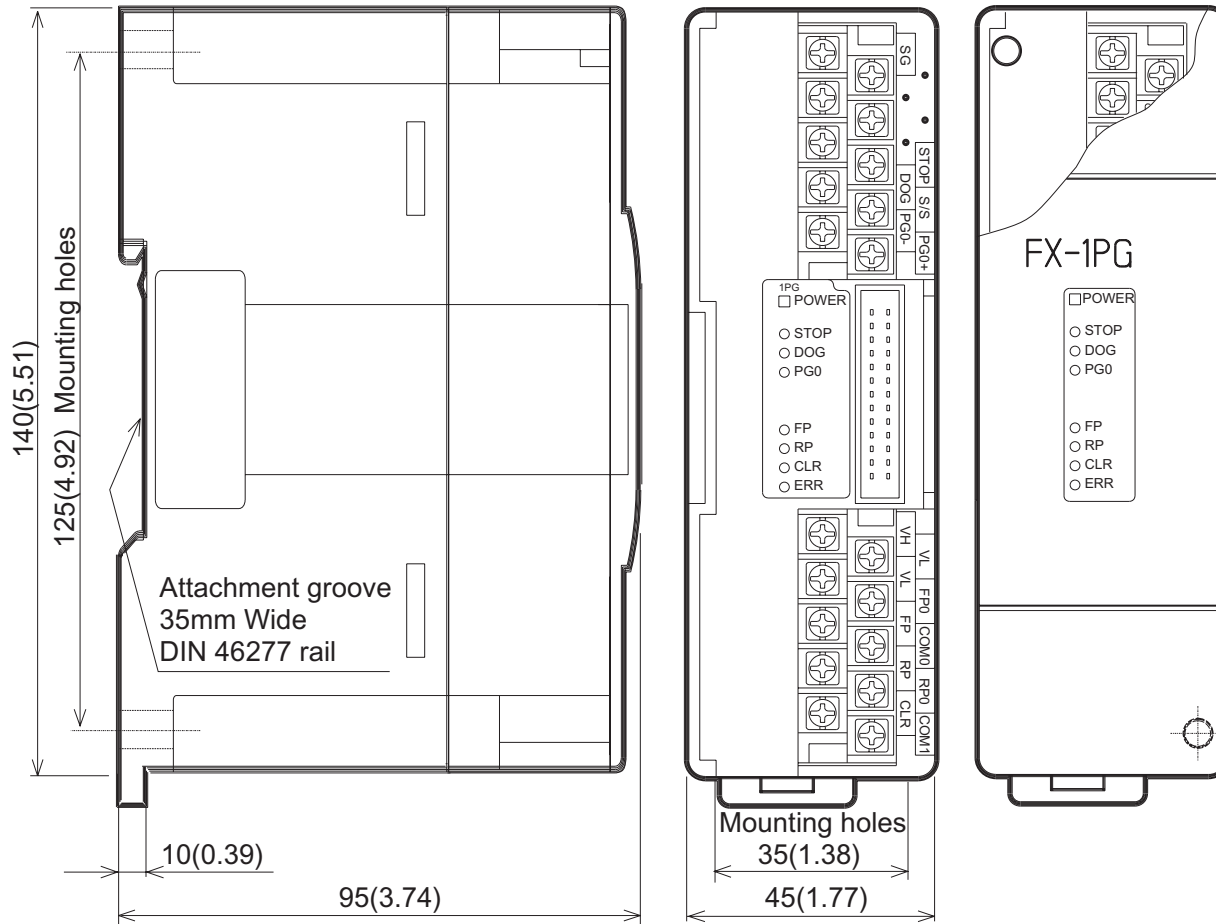

FX/FX<sub>2C</sub> Series PC or of an other extension block. The PGU can be installed using a DIN rail (DIN 46277, Width: 35 mm) or directly installed using M4 screws.

(For the details, refer to the handy manual packed together with the main unit.)

Mass(Weight): Approx. 0.3 kg (0.66 lbs)

Terminal screw: M3.5

Terminal screw tightening torque:  
0.5 to 0.8 N·m

Applicable terminals:

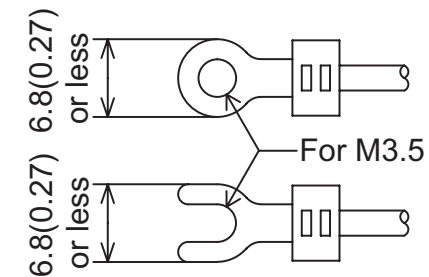

Accessories: No. labels for special modules

Dimensions : mm (inch)

- The PGU is installed to the right side of a main unit or an extension unit of an

FX<sub>2N</sub>-1PG

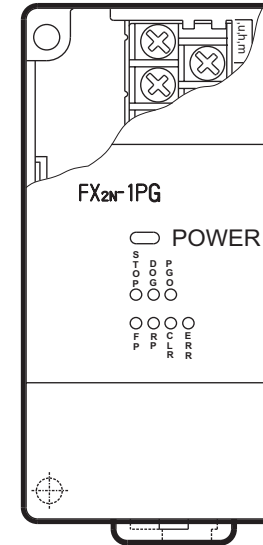
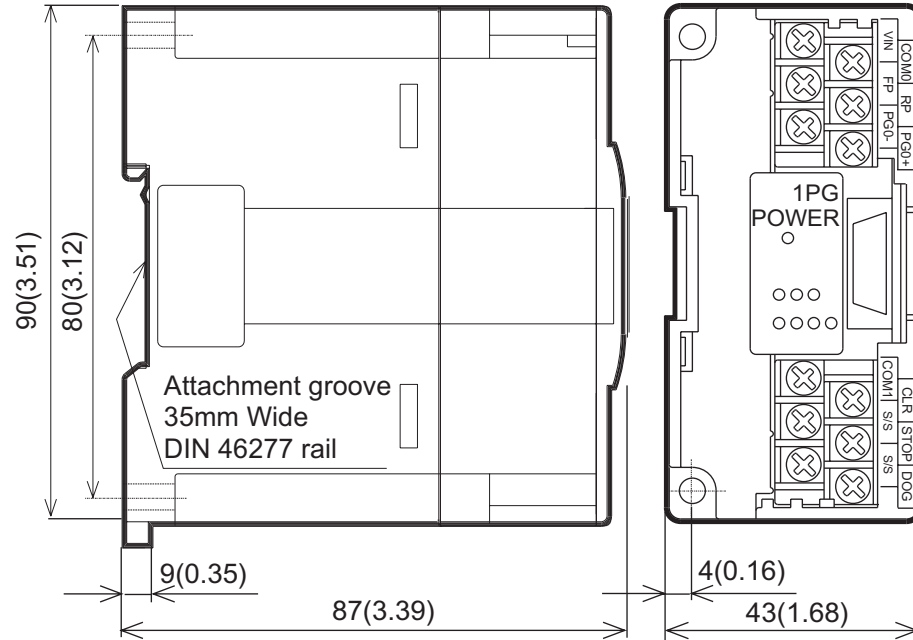

Mass(Weight): Approx. 0.2 kg (0.44 lbs)

Terminal screw: M3

Terminal screw tightening torque:  
0.5 to 0.8 N·m

Applicable terminals:

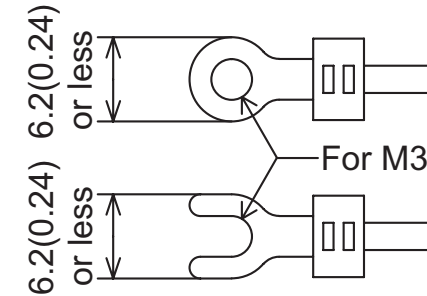

Accessories: No. labels for special modules

Dimensions : mm (inch)

- The PGU is installed to the right side of a main unit or an extension unit of an FX<sub>2N</sub> Series PC or of an other extension block. The PGU can be installed using a DIN rail (DIN 46277, Width: 35 mm) or directly installed using M4 screws. (For the details, refer to the handy manual packed together with the main unit.)

### 3. TERMINAL ARRANGEMENT

#### 3.1 Terminal Arrangement and LED Indication

FX-1PG

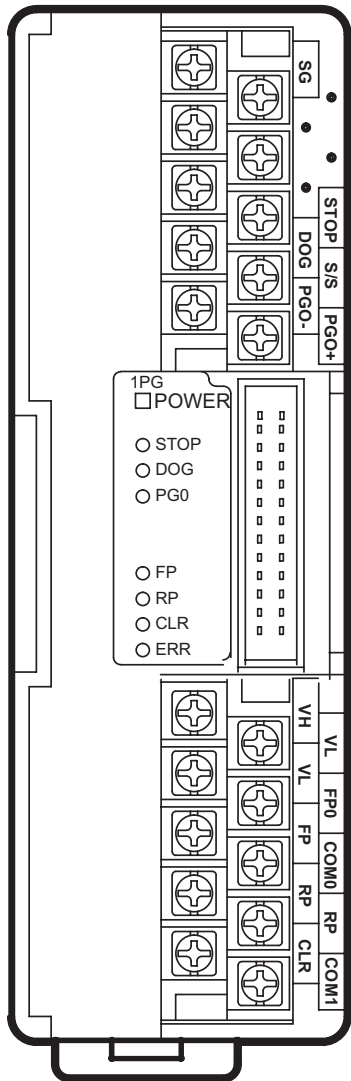

FX<sub>2N</sub>-1PG

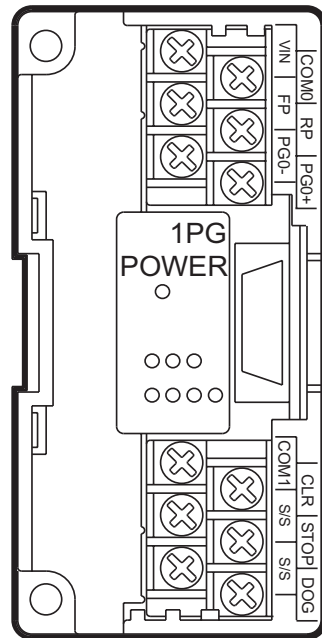

<LED allocation>

| Common between FX-1PG and FX <sub>2N</sub> -1PG |   |  |
|---|---|--|
| POWER   | Indicates power status of PGU.<br>Lighted when 5 V is supplied from PC.                 |  |
| STOP  | Lighted when stop command is entered.<br>Lighted by either STOP terminal or BFM #25 b1. |  |
| DOG   | Lighted when DOG input is entered.  |  |
| PG0   | Lighted when zero point signal is entered.  |  |
| FP  | Flashes when forward pulse or pulses are output.  | Output format can be modified using BFM #3 b8. |
| RP  | Flashes when reverse pulse or direction are output.                                     |  |
| CLR   | Lighted when CLR signal is output.  |  |
| ERR   | Flashes when error has occurred. Start command is not accepted when error has occurred. |  |

&lt; Terminal allocation &gt;

| FX-1PG | FX <sub>2N</sub> -1PG | Function  |
|--------|-----------------------|---|
| SG     | -                     | Signal ground. Short-circuit it to SG terminal of PC.   |
| STOP   |                       | DECELERATION STOP input.<br>Can function as stop command input in external command operation mode.  |
| DOG    |                       | Offers following different functions depending on operation mode.<br><ul style="list-style-type: none"> <li>• Machine home position return operation: NEAR POINT SIGNAL input</li> <li>• Interrupt single-speed operation: INTERRUPT input</li> <li>• External command operation: DECELERATION START input</li> </ul> |
| S/S    |                       | 24V DC power terminal for STOP input and DOG input<br>Connected to sensor power supply of PC or external power supply.  |
| PG0+   |                       | Power terminal for zero point signal<br>Connected to servo amplifier or external power supply (5 to 24V DC, 20 mA or less)  |
| PG0-   |                       | Enters zero point signal from drive unit or servo amplifier.<br>Response pulse width: 4 μs or more  |
| VH     | -                     | Power terminal for pulse output (supplied from servo amplifier or external unit)<br>24V DC±10% Current consumption: 15 mA   |
| VL     | -                     | Power terminal for pulse output (supplied from servo amplifier or external unit)<br>5 to 15V DC Current consumption: 20 mA  |
| -      | VIN                   | Power terminal for pulse output (supplied from servo amplifier or external unit)<br>5 to 24V DC, 35 mA or less  |
| FP0    | -                     | Pull-up resistance. Connected to VH or VL.  |
| FP     |                       | Terminal which outputs forward pulse or pulses. 100 kHz, 20 mA or less (5 to 24V DC)  |
| COM0   |                       | Common terminal for pulse output  |
| RP     |                       | Terminal which outputs reverse pulse or direction. 100 kHz, 20 mA or less (5 to 24V DC)   |
| RP0    | -                     | Pull-up resistance. Connected to VH or VL.  |
| COM1   |                       | Common terminal for CLR output  |
| CLR    |                       | Output for clearing deviation counter. 5 to 24V DC, 20 mA or less Output pulse width: 20 ms(Output when return to home position is completed or LIMIT SWITCH input is given.)   |
| ●      |                       | Spare terminal. Shall not be used a relay terminal.   |

## 4. SPECIFICATIONS

### 4.1 Specifications

#### < Environmental specifications >

The environmental specifications are equivalent to those of the main unit of the FX PC.

(For the details, refer to the handy manual packed together with the main unit.)

## &lt; Performance specifications &gt;

| Item                          | Specifications  |
|-------------------------------|---|
| Drive power supply            | ① +24V (for input signals) : 24V DC $\pm$ 10% Current consumption: 40 mA or less<br>Supplied from external power supply or 24+ output of PC.<br>② +5V (for internal control) : 5V DC, 55 mA Supplied from PC via extension cable.<br>③ For pulse output : 5V to 24V DC current consumption: 35mA or less  |
| Number of I/O points occupied | 8 input or output points of PC for each PGU   |
| Number of control axes        | 1 (A single PC can control independent 8 axes maximum.)   |
| Command speed                 | <ul style="list-style-type: none"> <li>● Operations are enabled at pulse speed of 10 Hz to 100 kHz.</li> <li>● Command unit can be selected among Hz, cm/min, 10 deg/min and inch/min.</li> </ul>   |
| Setting pulse                 | <ul style="list-style-type: none"> <li>● 0 to <math>\pm</math>999.999</li> <li>● Absolute position specification or relative travel specification can be selected.</li> <li>● Command unit can be selected among pulse, <math>\mu</math>m, mdeg and <math>10^{-4}</math> inch.</li> <li>● Multiplication of <math>10^0</math>, <math>10^1</math>, <math>10^2</math> or <math>10^3</math> can be set for position data.</li> </ul> |
| Pulse output format           | Forward (FP) and reverse (RP) pulse or pulse (PLS) with direction (DIR) can be selected.<br>Open collector and transistor output. 5 to 24V DC, 20 mA or less  |
| External I/O                  | <ul style="list-style-type: none"> <li>● Photocoupler insulation and LED operation indication are offered for every point.</li> <li>● 3 input points: (STOP/DOG) 24V DC, 7 mA and (PG0*1) 24V DC, 20 mA<br/>    (For details, refer to Section 8.1.)</li> <li>● 3 output points (FP/RP/CLR): 5 to 24V DC, 20 mA or less (For details, refer to Section 8.1.)</li> </ul>   |
| Communication with PC         | 16-bit RAM (without battery backup) buffer memories (BFMs) #0 to #31 are built in PGU.<br>Data communication with PC is performed using FROM/TO instructions.<br>32-bit data is processed by combining two BFMs. (For details, see to Section 5.1.)   |

\*1 One zero point signal PG0 is entered by flowing the current from the PG0+ terminal to the PG0- terminal.

## 5. BFM LIST

## 5.1 BFM List

\*1 Unit is  $\mu\text{m/R}$ ,  $\text{mdeg/R}$  or  $10^{-4}$  inch/R.

\*2 Unit is PLS,  $\mu\text{m/R}$ ,  $\text{mdeg/R}$  or  $10^{-4}$  inch depending on the system of units set in the BFM #3 b1 and b0.

| BFM No.        |               |   |                     |                    |                                |                                    |  |   |                                |                              |                                 |  |
|----------------|---------------|---|---------------------|--------------------|--------------------------------|------------------------------------|--|---|--------------------------------|------------------------------|---------------------------------|--|
| Higher 16 bits | Lower 16 bits | b15   | b14                 | b13                | b12                            | b11                                | b10  | b9  | b8                             | b7                           | b6                              |  |
|                | #0            | Pulse rate  |                     |                    |                                |                                    | A  | 1 to 32,767 PLS/REV (Pulse/Revolution)            |                                |                              |                                 |  |
| #2             | #1            | Feed rate   |                     |                    |                                |                                    | B  | 1 to 999,999 *1                                   |                                |                              |                                 |  |
|                | #3            | STOP input mode                                       | STOP input polarity | Count start timing | DOG input polarity             | —                                  | Home position return direction                               | Rotation direction                                | Pulse output format            | —                            | —                               |  |
| #5             | #4            | Maximum speed   |                     |                    |                                |                                    | $V_{\text{max}}$   | 10 to 100,000 Hz                                  |                                |                              |                                 |  |
|                | #6            | Bias speed  |                     |                    |                                |                                    | $V_{\text{bia}}$   | 0 to 10,000 Hz                                    |                                |                              |                                 |  |
| #8             | #7            | JOG speed   |                     |                    |                                |                                    | $V_{\text{JOG}}$   | 10 to 100,000 Hz                                  |                                |                              |                                 |  |
| #10            | #9            | Home position return speed (high speed)               |                     |                    |                                |                                    | $V_{\text{RT}}$  | 10 to 100,000 Hz                                  |                                |                              |                                 |  |
|                | #11           | Home position return speed (creep speed)              |                     |                    |                                |                                    | $V_{\text{CR}}$  | 10 to 10,000 Hz                                   |                                |                              |                                 |  |
|                | #12           | Number of zero point signals for home position return |                     |                    |                                |                                    | N  | 0 to 32,767 PLS                                   |                                |                              |                                 |  |
| #14            | #13           | Home position   |                     |                    |                                |                                    | HP   | 0 to $\pm 999,999$ *2                             |                                |                              |                                 |  |
|                | #15           | Acceleration/deceleration time                        |                     |                    |                                |                                    | $T_a$  | 50 to 5,000 ms                                    |                                |                              |                                 |  |
|                | #16           | Reserved  |                     |                    |                                |                                    |  |   |                                |                              |                                 |  |
| #18            | #17           | Set position (I)                                      |                     |                    |                                |                                    | P(I)   | 0 to $\pm 999,999$ *2                             |                                |                              |                                 |  |
| #20            | #19           | Operating speed (I)                                   |                     |                    |                                |                                    | V(I)   | 10 to 100,000 Hz                                  |                                |                              |                                 |  |
| #22            | #21           | Set position (II)                                     |                     |                    |                                |                                    | P(II)  | 0 to $\pm 999,999$ *2                             |                                |                              |                                 |  |
| #24            | #23           | Operating speed (II)                                  |                     |                    |                                |                                    | V(II)  | 10 to 100,000 Hz                                  |                                |                              |                                 |  |
|                | #25           | —   | —                   | —                  | Variable speed operation start | External command positioning start | Two speed positioning start                                  | Interrupt single speed positioning start          | Single speed positioning start | Relative / absolute position | Home position return start      |  |
| #27            | #26           | Current position                                      |                     |                    |                                |                                    | CP   | Automatic writing -2,147,483,648 to 2,147,483,647 |                                |                              |                                 |  |
|                | #28           | —   | —                   | —                  | —                              | —                                  | —  | —   | Positioning completed flag     | Error flag                   | Current position value overflow |  |
|                | #29           | Error code  |                     |                    |                                |                                    | Error code is automatically written when error has occurred. |   |                                |                              |                                 |  |
|                | #30           | Model code  |                     |                    |                                |                                    | "5110" is automatically written.                             |   |                                |                              |                                 |  |
|                | #31           | Reserved  |                     |                    |                                |                                    |  |   |                                |                              |                                 |  |



\*3 Only one bit among the BFM #25 b6 to b4 and b12 to b8 can be turned on. If two or more bits among them are turned on, no operation is performed.

\*4 When data is written into the BFMs #0, #1, #2, #3, #4, #5, #6 and #15, data is calculated inside the PGU during the first positioning operation. To save this processing time (500 ms maximum).

| b5   | b4             | b3                 | b2                             | b1   | b0          | R: For read<br>W: For write |     |
|--|----------------|--------------------|--------------------------------|--|-------------|-----------------------------|-----|
| Initial value: 2,000 PLS/REV                                       |                |                    |                                |  |             | R/W                         |     |
| Initial value: 1,000 PLS/REV                                       |                |                    |                                |  |             |                             |     |
| Position data multiplication<br>10 <sup>0</sup> to 10 <sup>3</sup> |                | —                  | —                              | System of units<br>[Motor system, Machine system, Combined system] |             |                             |     |
| Initial value: 100,000 Hz  |                |                    |                                |  |             |                             |     |
| Initial value: 0 Hz  |                |                    |                                |  |             |                             |     |
| Initial value: 10,000 Hz   |                |                    |                                |  |             |                             |     |
| Initial value: 50,000 Hz   |                |                    |                                |  |             |                             |     |
| Initial value: 1,000 Hz  |                |                    |                                |  |             |                             |     |
| Initial value: 10 PLS  |                |                    |                                |  |             |                             |     |
| Initial value: 0   |                |                    |                                |  |             |                             |     |
| Initial value: 100 ms  |                |                    |                                |  |             |                             |     |
| —  |                |                    |                                |  |             |                             |     |
| Initial value: 0   |                |                    |                                |  |             |                             | R/W |
| Initial value: 10 Hz   |                |                    |                                |  |             |                             |     |
| Initial value: 0   |                |                    |                                |  |             |                             |     |
| Initial value: 10 Hz   |                |                    |                                |  |             |                             |     |
| JOG- operation   | JOG+ operation | Reverse pulse stop | Forward pulse stop             | STOP   | Error reset |                             |     |
| PG0 input ON   | DOG input ON   | STOP input ON      | Home position return completed | Reverse rotation/ Forward rotation                                 | Ready       | R                           |     |
| —  |                |                    |                                |  |             |                             |     |

- When the power of the PGU is turned off, the BFM data is cleared. When the power of the PGU is turned on, the initial values are entered to the BFMs.
- The BFMs #0, #1 and #2 are neglected when the BFM #3 (b1, b0) is set to the motor system.
- When each BFM is written or read, 16-bit data shall be written/read in the unit of 16 bits and 32-bit data shall be written/read in the unit of 32 bits.

< Reading of 32-bit data >

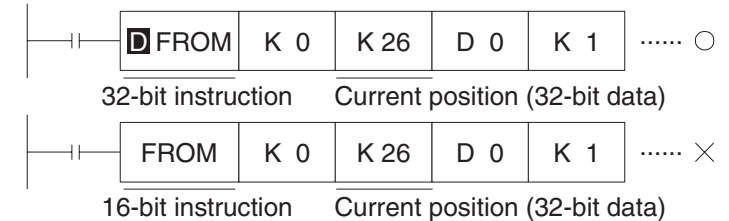

- At BFM #19 and #20, variable speed operation and external command positioning operation, can set a negative value. (-10 to -100,000 Hz)

## 5.2 System of Units and Parameter Setting

### [ BFM #0 ] Pulse rate

A: 1 to 32, 767 P/R

This is the number of input pulses required by the amplifier to rotate the motor by 1 revolution. It is not the number of encoder pulses per revolution of the motor. (The pulse rate becomes a different value in accordance with the electronic gear ratio.)

The BFM#0 is not required to be set when the motor system of units described later is selected.

### [ BFMs #2 and #1 ] Feed rate

B1 (distance specification) = 1 to 999,999  $\mu\text{m}/\text{R}$

B2 (angle specification) = 1 to 999,999  $\text{mdeg}/\text{R}$

B3 (distance specification) = 1 to 999,999  $\times 10^{-4}$  inch/R

This is the machine travel B while the motor rotates by 1 revolution. Set either one among B1, B2 and B3 in accordance with the unit among  $\mu\text{m}/\text{R}$ ,  $\text{mdeg}/\text{R}$  and  $10^{-4}\text{inch}/\text{R}$  suitable to the application.

The BFMs #2 and #1 are not required to be set when the motor system of units described later is selected.

### [ BFM #3 ] Parameters (b0 to b15)

Set bits 0 to 15 as follows.

#### ① System of units (b1, b0)

| b1 | b0 | System of units | Remarks  |
|----|----|-----------------|--|
| 0  | 0  | Motor system    | Units based on pulses  |
| 0  | 1  | Machine system  | Units based on lengths and angles  |
| *1 | 0  | Combined system | Units based on lengths and angles for position units based on Hz for speed |
| *1 | 1  |                 |  |

\*1 Offers the same operation.

The table below shows the units for position and speed in accordance with the setting of the BFMs #2 and #1 (feedrate).

|                 | Selection of feedrate | Motor system | Combined system      | Machine system |
|-----------------|-----------------------|--------------|----------------------|----------------|
| Position data*2 | B1                    | PLS          | $\mu\text{m}$        |                |
|                 | B2                    | PLS          | $\text{mdeg}$        |                |
|                 | B3                    | PLS          | $10^{-4}\text{inch}$ |                |
| Speed data*3    | B1                    |              | Hz                   | cm/min         |
|                 | B2                    |              | Hz                   | 10deg/min      |
|                 | B3                    |              | Hz                   | inch/min       |

\*2 Position data: HP, P(I), P(II), CP

\*3 Speed data:  $V_{\text{max}}$ ,  $V_{\text{bia}}$ ,  $V_{\text{JOG}}$ ,  $V_{\text{RT}}$ , V(I), V(II)

② Multiplication of position data (b5, b4)

| b5 | b4 | Multiplication  |
|----|----|-----------------|
| 0  | 0  | 10 <sup>0</sup> |
| 0  | 1  | 10 <sup>1</sup> |
| 1  | 0  | 10 <sup>2</sup> |
| 1  | 1  | 10 <sup>3</sup> |

The position data HP, P(I), P(II) and CP will be multiplied by the value shown in the table on the left.

Example: When the value of the set position P(I) (BFMs #18 and #17) is 123 and the BFM #3 (b5, b4) is (1, 1), the actual position (or travel) becomes as follows:

|                          |  |
|--------------------------|--|
| Motor system of units    | $123 \times 10^3 = 123,000$ (pulses)   |
| Machine system of units  | $123 \times 10^3 = 123,000$<br>( $\mu\text{m}, \text{mdeg}, 10^{-4} \text{inch}$ ) |
| Combined system of units | $= 123$<br>( $\text{mm}, \text{deg}, 10^{-1} \text{inch}$ )                        |

③ Pulse output format (b8)

The pulse output terminals FP and RP of the PGU change as follows in accordance with the setting (0 or 1) of b8.

- When b8 = 0: Forward pulse (FP) and reverse pulse (RP)

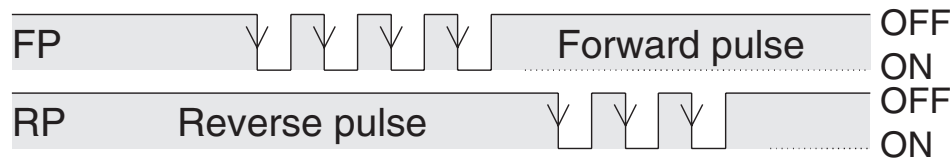

- When b8 = 1: Pulse (PLS) with direction (DIR)

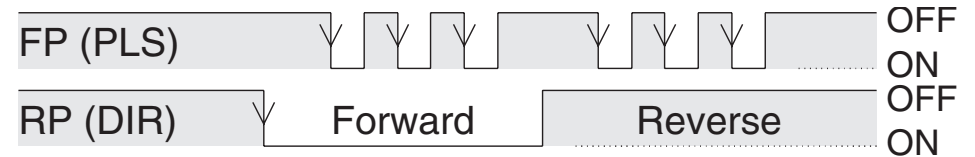

④ Rotation direction (b9)

- When b9 = 0: The current position (CP) value increases with a forward pulse (FP).
- When b9 = 1: The current position (CP) value decreases with a forward pulse (FP).

This bit is used for the initial setting. The rotation direction is not required to be changed in every actual operation.

⑤ Home position return direction (b10)

- When b10 = 0: The current position (CP) value decreases during return to the home position.
- When b10 = 1: The current position (CP) value increases during return to the home position.

⑥ DOG input polarity (b12)

- When b12 = 0: The DOG (near point signal) input is turned on when the workpiece is coming near the home position.
- When b12 = 1: The DOG (near point signal) input is turned off when the workpiece is coming near the home position.

## ⑦ Count start point (b13)

See Sections 6.1.1 to 6.1.3.

This bit specifies the point at which counting of zero point signals is started.

- When b13 = 0: Counting of zero point signals is started when the DOG input is given (when DOG input is turned on if b12 is set to 0 or when DOG input is turned off if b12 is set to 1).
- When b13 = 1: Counting of zero point signals is started when the DOG input is given once, then stopped.

## ⑧ STOP input polarity (b14)

- When b14 = 0: The operation is stopped when the input is turned on (OFF during operation).
- When b14 = 1: The operation is stopped when the input is turned off (ON during operation).

This polarity changeover is valid exclusively for the STOP input in the PGU.

<Note> BFM #3

| b15             | b14                 | b13               | b12                       | b11 | b10                            | b9                 | b8           | b7 | b6 | b5                              | b4 | b3 | b2          | b1 | b0 |
|-----------------|---------------------|-------------------|---------------------------|-----|--------------------------------|--------------------|--------------|----|----|---------------------------------|----|----|-------------|----|----|
| Stop input mode | Stop input polarity | Count start point | Polarity of the DOG input | 0   | Home position return direction | Rotation direction | Pulse format | 0  | 0  | Multiplication of position data | 0  | 0  | Unit system |    |    |

Write hexadecimal H□□□□ in BFM #3 in accordance with the 0 and 1 status of each bit. Set b2, b3, b6, b7 and b11 to 0.

## ⑨ STOP input mode (b15)

- When b15 = 0: The operation is interrupted when the stop command is given (from the PGU or the PC) during operation, then the operation for the remaining distance is restarted when the restart command is given. The Jog drive begins again when the stop command is turned off from turning on when the Jog command has been turned on.
  - \* However, if any BFM (except #25) is rewritten while operation is interrupted by the stop command, the operation for the remaining distance will not be performed. Write the BFMs by pulse operation (except the BFM #25).
- When b15 = 1: The operation for the remaining distance is not performed, but the next positioning is performed. The Jog drive begins again when the stop command is turned off from turning on when the Jog command has been turned on.

### 5.3 Speed Data and Position Data

#### [ BFM #5 and #4 ] Maximum speed $V_{\max}$

Motor system and combined system:  
10 to 100,000 Hz

Machine system: 1 to 153,000

This is the maximum speed. Make sure that the bias speed (BFM #6), the JOG speed (BFMs #7 and #8), the home position return speed (BFMs #9 and #10), the creep speed (BFM #11), the operating speed (I) (BFMs #19 and #20) and the operating speed (II) (BFMs #23 and #24) are set respectively to a value equivalent to or less than the maximum speed.

The degree of acceleration/deceleration is determined by this maximum speed, the bias speed (BFM #6) and the acceleration/deceleration time (BFM #15).

#### [ BFM #6 ] Bias speed $V_{\text{bia}}$

Motor system and combined system:  
0 to 10,000 Hz

Machine system: 0 to 15,300

This is the bias speed at time of start.

When the FX(2N)-1PG and the stepper motor are used together, set a value while taking the resonance area and the self-start frequency of the stepper motor into account.

#### [ BFM #8 and #7 ] JOG speed $V_{\text{JOG}}$

Motor system and combined system:  
10 to 100,000 Hz

Machine system: 1 to 153,000

This is the speed for manual forward/reverse (JOG+/JOG-).

Set a value between the bias speed  $V_{\text{bia}}$  and the maximum speed  $V_{\max}$ .

#### [ BFM #10 and #9 ] Home position return speed (high speed) $V_{\text{RT}}$

Motor system and combined system:  
10 to 100,000 Hz

Machine system: 1 to 153,000

This is the speed (high speed) for returning to the machine home position.

Set a value between the bias speed  $V_{\text{bia}}$  and the maximum speed  $V_{\max}$ .

#### [ BFM #11 ] Home position return speed (creep) $V_{\text{CR}}$

Motor system and combined system:  
10 to 10,000 Hz

Machine system: 1 to 15,300

This is the speed (extremely slow speed) after the near point signal (DOG) for returning to the machine home position.

It is the speed immediately before stopping in the machine home position. It is recommended to set it as slow as possible so that the precision of the home position becomes better.

#### [ BFM #12 ] Number of zero point signals for home position return $N$

0 to 32,767 PLS

This is the number of zero point signals counted for returning to the machine home position.

When the zero point signal is not used and the machine should be stopped immediately by only the DOG input, set the BFM #12 to 0. However, pay rigid attention so

that the machine is not damaged when it is immediately stopped from high-speed operation.

### [ BFM #14 and #13 ] Home position HP

Motor system: 0 to  $\pm 999,999$  PLS  
Machine system and combined system:  
0 to  $\pm 999,999$

This is the home position used for returning to the machine home position.

When the home position return operation is completed, the value set here is written to the current position (BFMs #26 and #27).

### [ BFM #15 ] Acceleration/deceleration time Ta

50 to 5,000 ms

This is the time between the bias speed (BFM #6) and the maximum speed (BFMs #5 and #4).

The degree of acceleration/deceleration is determined by the maximum speed, the bias speed and the acceleration/deceleration time.

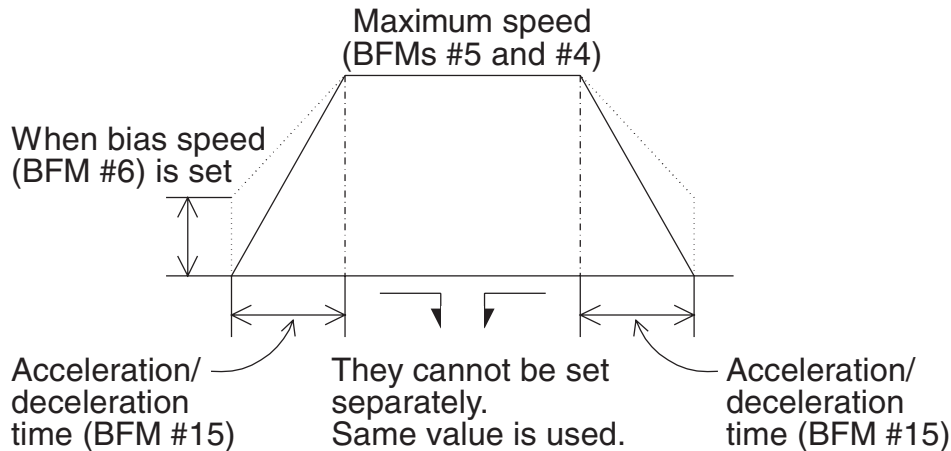

### [ BFM #18 and #17 ] Set position (I) P(I)

Motor system: 0 to  $\pm 999,999$  PLS  
Machine system and combined system:  
0 to  $\pm 999,999$

This is the target position or the travel distance for operation.

When the absolute position is used, the rotation direction is determined in accordance with the absolute value of the set position based on the current position (BFMs #26 and #27).

When the relative position is used, the rotation direction is determined by the sign of the set position.

### [ BFM #20 and #19 ] Operating speed (I) V(I)

Motor system and combined system:  
10 to 100,000 Hz  
Machine system:  
1 to 153,000

This is the actual operating speed within the range between the bias speed  $V_{bia}$  and the maximum speed  $V_{max}$ .

In variable speed operation and external command positioning operation, forward rotation or reverse rotation is performed in accordance with the sign (positive or negative) of this set speed.

### [ BFM #22 and #21 ] Set position (II) P(II)

Motor system: 0 to  $\pm 999,999$  PLS  
Machine system and combined system:  
0 to  $\pm 999,999$

This is the set position for the second speed in two-speed positioning operation.

**[ BFMs #24 and #23 ] Operating speed (II) V(II)**

Motor system and combined system: 10 to 100,000 Hz  
 Machine system: 1 to 153,000

This is the second operating speed in two-speed positioning operation within the range between the bias speed V<sub>bia</sub> and the maximum speed V<sub>max</sub>.

**[ BFMs #27 and #26 ] Current position CP**

Motor system: -2,147,483,648 to +2,147,483,647 Hz  
 Machine system and combined system: -2,147,483,648 to +2,147,483,647

The current position data is automatically written here. When the value set here is read by the PC for monitoring, make sure to read it in the unit of 32 bits.

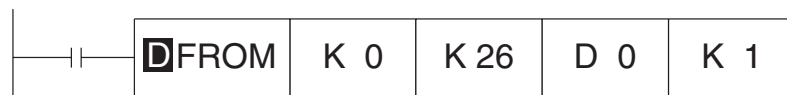

32-bit instruction

**< Conversion of system of units >**

The following relationship is present between the motor system of units and the machine system of units. They are automatically converted each other.

$$\begin{matrix} \text{Speed command} \\ \text{cm/min, 10deg/min, inch/min} \end{matrix} \times \frac{A \times 10^4}{B1, B2 \text{ or } B3}$$

= Speed command (Hz) x 60

A indicates the pulse rate. B1 to B3 indicate the feedrate. PPS indicates the pulses per second. When setting the speed data using the machine system of units, make sure that the value converted into pulses is within the range determined for the motor system and the combined system (Hz).

**< Stepwise speed command value >**

The frequency f of the pulse generated in the PGU is stepwise as follows.

$$f = \frac{1}{0.25n} \times 10^6 = 10 \text{ to } 100,000 \text{ Hz}$$

Where, n: Integer in range of 40 to 400,000  
 For example, in the case of n = 40, f = 100,000 Hz  
 in the case of n = 41, f = 97,560 Hz

Any pulse whose frequency is between the two values above cannot be generated.

## 5.4 Position Data, Home Position and Current Position

- The position data includes the following:  
HP: Home position, P(I): Set position (I), P(II): Set position (II) and CP: Current position  
The unit and the multiplication of each item are described in Section 5.2.
- When the operation of returning to the machine home position is completed, the home position HP (BFMs #14 and #13) value is automatically written to the current position CP (BFMs #27 and #26). The figure below shows the CP value when the home position HP is -100.

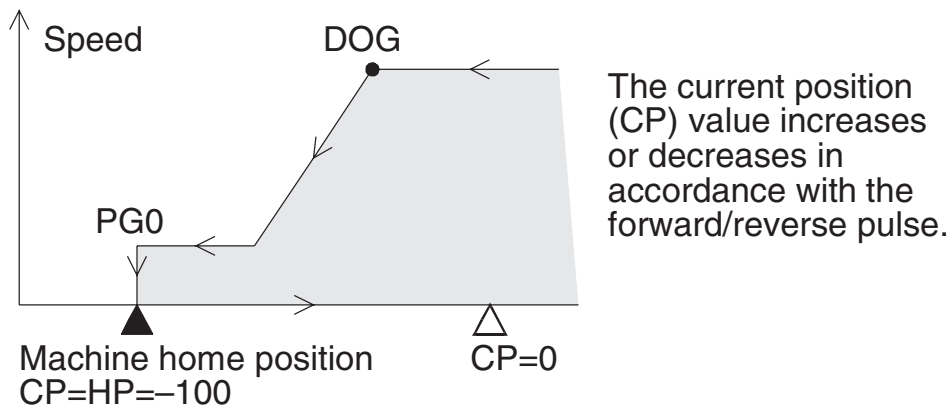

- The set positions P(I) and P(II) can be treated as absolute positions (distance from the current position  $CP = 0$ ) or relative positions (travel from the current stop position) as described later.

### < Error in command between the machine system of units and the combined system of units >

When the pulse rate of the BFM #0 (#2, #1) is supposed the pulse rate as A, the feedrate as B and the relative travel distance as C, the value " $C \times (A/B)$ " indicates the pulse quantity which should be generated by the PGU. Even if the value " $(A/B)$ " is not an integer, error is not generated in the command if the value " $C \times (A/B)$ " is an integer.

However, if the value " $C \times (A/B)$ " is not an integer, accumulated error is generated in the current position when relative movement is repeated. When the absolute is used for operation, an error less than 1 pulse may be generated by counting fractions over 1/2 as one and disregarding the rest, but accumulated error is not generated.

When the motor system of units is used, such an accumulated error is not generated.



## 5.5 Operation Command

### [ BFM #25 ] Operation command (b0 to b11, b12)

After data is written to the BFM #0 to #24, write the BFM #25 (b0 to b12) as follows.

- [b0]** When b0 = 1: Error reset  
The error flag (BFM #28 b7) described later is reset. When the error occurs, the positioning completion signal (BFM #28 b8) is reset.
- [b1]** When b1 = 0 → 1: Stop  
This bit functions in the same way with the STOP input in the PGU, but the stop operation can be performed from the sequence program in the PC.  
However, if this bit is changed from 0 to 1 before the STOP input is given in the PGU in the external command positioning mode, the machine is decelerated and stopped.
- [b2]** When b2 = 1: Forward pulse stop  
The forward pulse is immediately stopped in the forward limit position.
- [b3]** When b3 = 1: Reverse pulse stop  
The reverse pulse is immediately stopped in the reverse limit position.
- [b4]** When b4 = 1: JOG+ operation  
When b4 continues to be 1 for less than 300 ms, one forward pulse is generated.  
When b4 continues to be 1 for 300 ms or more, continuous forward pulses are generated.
- [b5]** When b5 = 1: JOG- operation  
When b5 continues to be 1 for less than 300 ms, one reverse pulse is generated.  
When b5 continues to be 1 for 300 ms or more, continuous reverse pulses are generated.
- [b6]** When b6 = 0 → 1: Home position return start  
The machine starts to return to the home position, and is stopped at the machine home position when the DOG input (near point signal) or the PG0 (zero point signal) is given.
- [b7]** When b7 = 0: Absolute position  
When b7 = 1: Relative position  
The relative or absolute position is specified in accordance with the b7 status (1 or 0).  
(This bit is valid while operation is performed using b8, b9 or b10.)
- [b8]** When b8 = 0 → 1: Single-speed positioning operation start  
Single-speed positioning operation is performed.  
For the details, see Section 6.2.
- [b9]** When b9 = 0 → 1: Interrupt single-speed positioning operation start  
Interrupt single-speed positioning operation is performed.  
For the details, see Section 6.2.
- [b10]** When b10 = 0 → 1: Two-speed positioning operation start  
Two-speed positioning operation is performed.  
For the details, see Section 6.3.

- [b11] When b11 = 0 → 1: External command positioning operation start  
External command positioning operation is performed. The rotation direction is determined by the sign of the speed command.  
For the details, see Section 6.3.
- [b12] When b12 = 1: Variable speed operation  
Variable speed operation is performed.  
For the details, see Section 6.4.

< Operation command data transfer method >

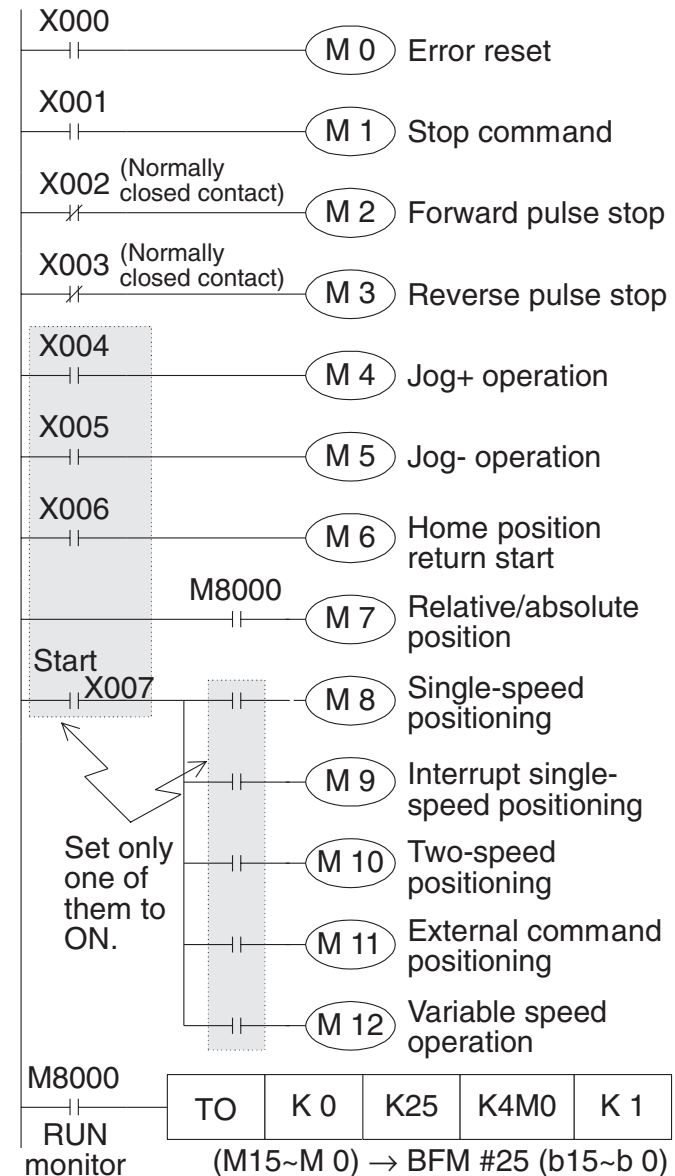

- Error can be reset by forcibly turning on/off the peripheral unit. The input X000 does not have to be used.  
When the data on absence/presence of error and the error code should be saved even after power interrupt, use the auxiliary relays or data registers backed up by the battery.
- The stop command is generally provided in the PGU, and is also output from the sequence program in the PC. In such a case, the input X001 is not required.
- In operation which does not require returning to the home position such as inching operation with a constant feedrate, the input X006 is not required.
- When which one between the relative and absolute positions should be used is always determined, drive the M7 using the M8000 or set the M7 always to OFF.
- Drive one of the M8 to M12 using the M8000.

If two or more of them are turned on, operation is disabled. (See Section 6.4.)

- As the general start command, create an appropriate sequence using the input X007 to drive the M8 to M12. (See Section 9.1.)  
The time after the FX<sub>(2N)</sub>-1PG receives the start command until it generates a pulse is approximately 10 ms usually. However, 500 ms maximum is required for the first operation after the PC starts running or for the first operation after the BFM#0, #1, #2, #3, #4, #5, #6 or #15 is written.
- The TO instruction is a write instruction from the PC to the BFM. In the example on the left, the PGU is connected as a special unit in the position nearest the main unit.
- In the program below, the start bit for the operation mode cannot be set to OFF inside the PGU, so operation from the second time and later cannot be performed. Correct it as shown in the right.

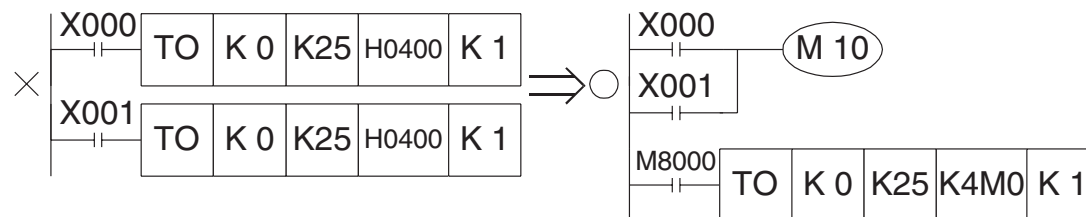

## 5.6 Status and Error Codes

The status information to notify the PC of the PGU status is automatically saved in the BFM #28. Read it into the PC using the FROM instruction.

### [ BFM #28] Status information (b0 to b8)

- [b0]** When b0 = 0: BUSY  
When b0 = 1: READY  
This bit is set to BUSY while the PGU is generating pulses.
- [b1]** When b1 = 0: Reverse rotation  
When b1 = 1: Forward rotation  
This bit is set to 1 when operation is started with forward pulse.
- [b2]** When b2 = 0: Home position return unexecuted  
When b2 = 1: Home position return completed  
When returning to the home position is completed, b2 is set to 1, and continues to be 1 until the power is turned off. To reset b2, use the program.  
[ In the FX-1PG manufactured in November, 1993 or later (Serial No. 3Y\*\*\*\* or later), b2 can be reset by the program.  
In every FX<sub>2N</sub>-1PG, b2 can be reset by the program. ]  
Connect b2 in series to the start command.  
**(Program example to reset b2)**  
Write "K0" to the BFM #28 (status information) using the TO (P) instruction.  
By this program, b2 (home position return completed) only in the BFM #28 is reset and rewritten to 0.

"Home position  
return completed"  
bit reset input

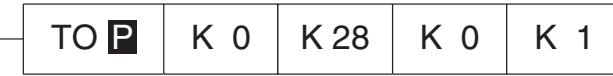

BLK No. BFM No. Written Number of  
value transfer points

- [b3]** When b3 = 0: STOP input OFF  
When b3 = 1: STOP input ON
- [b4]** When b4 = 0: DOG input OFF  
When b4 = 1: DOG input ON
- [b5]** When b5 = 0: PG0 input OFF  
When b5 = 1: PG0 input ON  
Any of them represents the ON/OFF status of the PGU input as it is.
- [b6]** When b6 = 1: Current position value overflow  
The 32-bit data saved in the BFMs (#27 and #26) has overflowed. This bit is reset when returning to the home position is completed or the power is turned off.
- [b7]** When b7 = 1: Error flag  
b7 becomes 1 when an error has occurred in the PGU, and the contents of the error are saved in the BFM #29.  
This error flag is reset when the BFM #25 b0 becomes 1 or the power is turned off.
- [b8]** When b8 = 0: Positioning started  
When b8 = 1: Positioning completed  
b8 is cleared when positioning is started home position return start, or error reset (only when error occurs), and set when positioning is completed. b8 is also set when returning to the home position is completed.

- Various start commands are accepted exclusively while the BFM #28 b0 is set to 1 (READY).
- Various data is also accepted exclusively while the BFM #28 b0 is set to 1 (READY). However, the BFM #25 b1 (stop command), the BFM #25 b2 (forward pulse stop) and the BFM #25 b3 (reverse pulse stop) are accepted even while the BFM #28 b0 is set to 0 (BUSY).
- The data can be read from the PGU to the PC without regard to the setting of the BFM #28 b0.
- The current position is changed accompanied by generation of pulses even while the BFM #28 b0 is set to 0 (BUSY).

< Reading of status information >

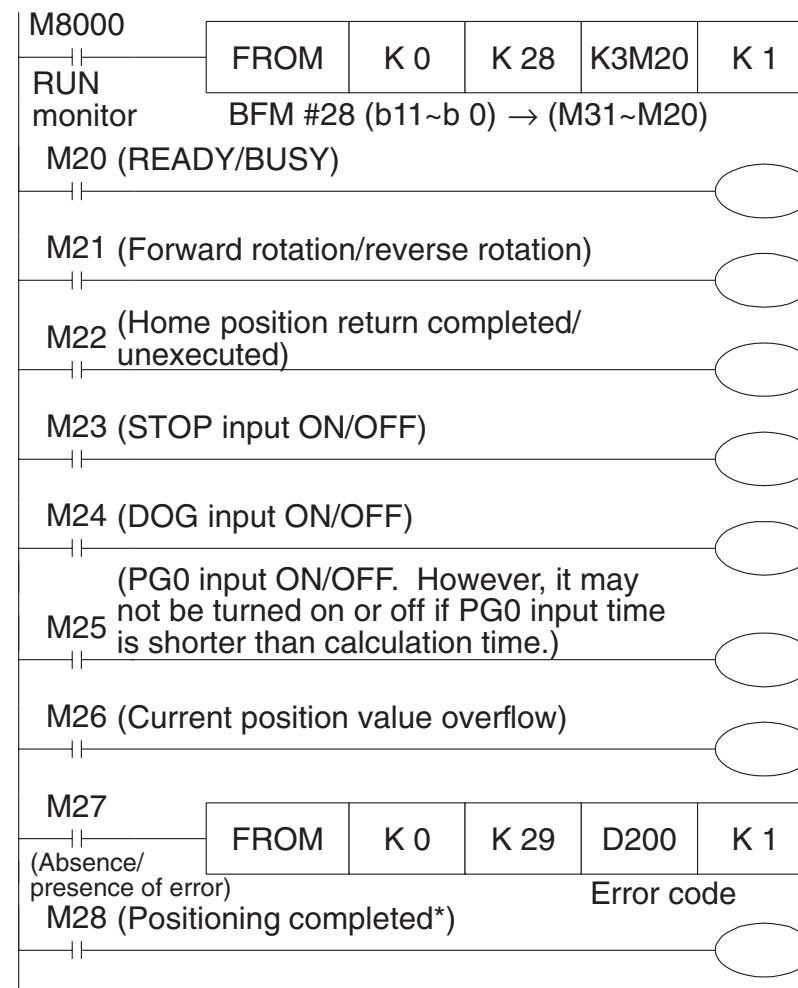

\* When a drive amplifier for a stepper motor without the positioning completed output is used, this signal can be used for recognition of positioning completed and the next operation can be started.

**< Error code No. > [ BFM #29 ]**

The following error code Nos. are saved in the BFM #29. Read and check it when the BFM #28 b7 is set to 1 (Error present).

OO1: Large/small relationship is incorrect. ( $V_{max} < V_{bia}$  or  $V_{RT} < V_{CR}$ )

OO indicates the lower word No. of the related BFM.

OO2: Setting is not performed yet. (V(I), P(I), V(II) or P(II))

However, V(II) and P(II) should be set exclusively in two-speed operation or external command operation.

OO indicates the corresponding BFM No. For example, "172" indicates that the BFMs #18 and #17 are set to 0.

OO3: Setting range is incorrect.

OO indicates the corresponding BFM No. For example, "043" indicates that the BFMs #5 and #4 are set to a value outside the range of 10 to 100,000 PPS.

- When a speed command specifies a value equivalent to or more than  $V_{max}$  or a value equivalent to or less than  $V_{bia}$ , error does not occur.  $V_{max}$  or  $V_{bia}$  is used for operation.
- Though the ready status can be specified even while an error is present, the start command is not accepted.

# **MEMO**

## 6. OUTLINE OF OPERATION MODES

### 6.1 JOG Operation and Machine Home Position Return Operation

Seven operation modes are available in the PGU in accordance with the start command type. The data on speed and position should be transferred preliminarily from the PC to the buffer memories (BFMs) of the PGU. The transfer data addresses are BFMs #0 to #25 which are allocated as described in Section 5.1.

#### ■ JOG operation

While the forward or reverse button is pressed and held, the motor is driven forward or in reverse.

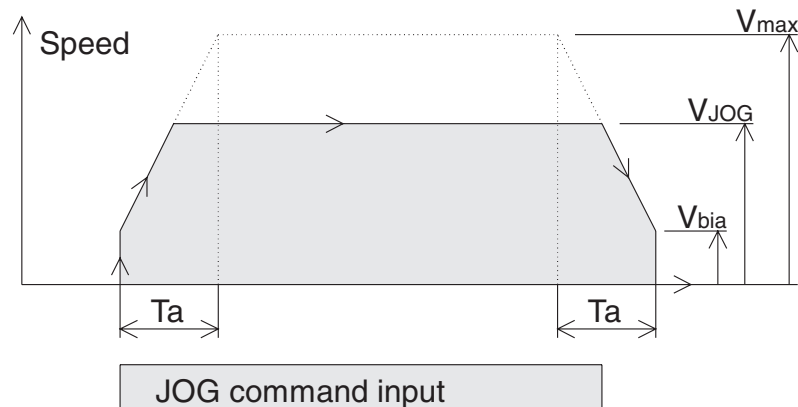

Any value between the bias speed  $V_{bia}$  (BFM #6) and the maximum speed  $V_{max}$  (BFMs #5 and #4) is valid as the command speed  $V_{JOG}$  (BFMs #8 and #7). The acceleration/deceleration time  $T_a$  (BFM #15) is the time between  $V_{bia}$  and  $V_{max}$ .

$V_{max}$ ,  $V_{bia}$  and  $T_a$  are equivalent in the operation modes described later.

#### ■ Machine home position return operation

When the home position start command is received, the motor makes the machine return to the home position. When returning to the home position is completed, the home position HP (BFMs #14 and #13) value is written to the current position CP (BFMs #27 and #26).

Position ④ in the figure below indicates the machine home position.

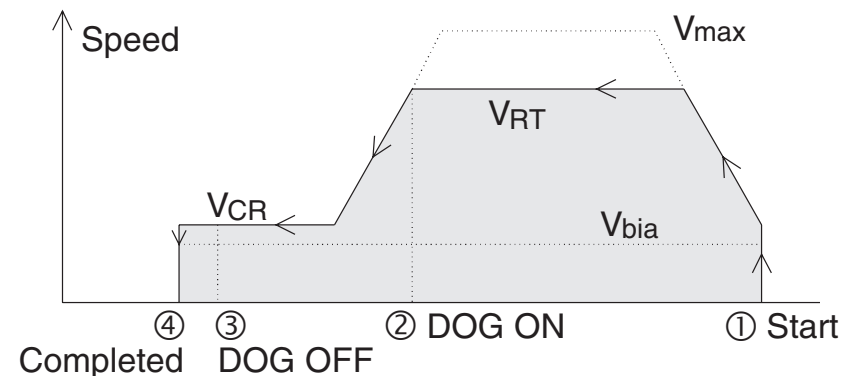

- ① When the home position return start command is changed from OFF to ON, the home position return operation is started at the speed  $V_{RT}$  (BFMs #10 and #9).
- ② When the near point signal DOG input is turned on, the motor decelerates to the creep speed  $V_{CR}$  (BFM #11).
- ③ When the near point signal DOG input is changed from ON to OFF and the motor zero point signal PG0 is received (There is setting by BFM #3 b13), the motor is immediately stopped in the position ④. The value of the home position address is written in the home position value by generating a clear signal. For the details, refer to Sections 6.1.1 to 6.1.4.



### 6.1.1 DOG Switch

#### < DOG switch for returning to home position >

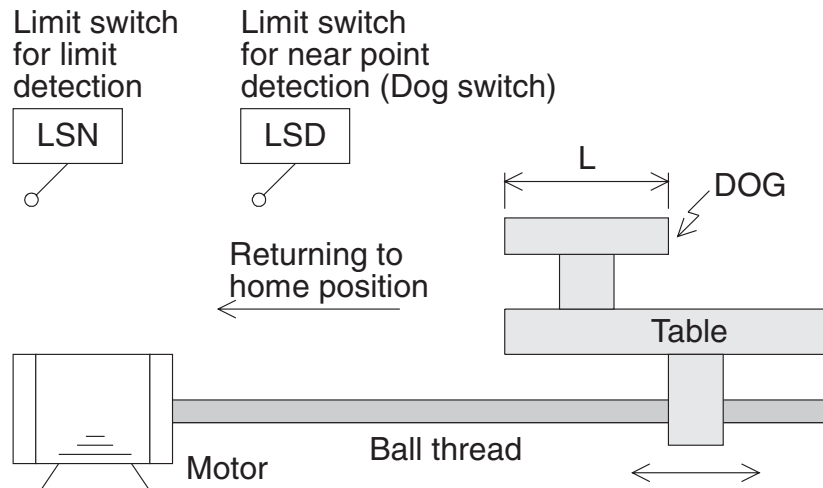

- A dog whose length is  $L$  is fixed to a table driven in the left and right direction by a servo motor via a ball thread.
- When the table moves in the home position return direction, the dog is in contact with the limit switch (LSD) for near point detection, and the LSD is actuated.
- The LSD is turned ON from OFF when the BFM #3 b12 is set to 0, and turned OFF from ON when the BFM #3 b12 is set to 1.
- The home position return direction is determined by the BFM #3 b9 (rotation direction) and b10 (home position return direction).
- The limit switch LSD is often referred to as dog switch. The actuation point of the dog switch is rather dispersed.

It is not always actuated at one same point, which will affect the repeatability of the home position return operation.

On the other hand, the servo amplifier outputs one zero point signal PG0 (Z phase signal 0P) for each revolution of the servo motor.

For example, if the table is moved by 1 mm per revolution of the servo motor, one PG0 signal is output for every 1 mm movement of the table.

Accordingly, if the dog switch is adjusted so that it is actuated within the interval between two PG0 signals and the PG0 signal is used for returning to the home position, dispersion in actuation of the dog switch can be neglected. The repeatability of the home position return operation is assured.

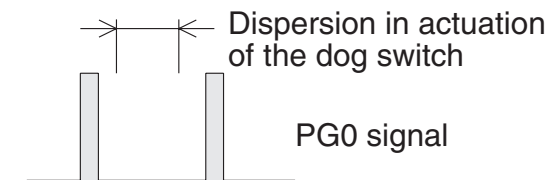

### 6.1.2 Overshoot Detection Home Return Positioning Method

#### < Overshoot detection home return positioning method >

- With this method, the motor starts deceleration when the dog is in contact with the dog switch, and the motor is stopped immediately when one (or several) zero point signal PG0 is received after the dog has passed the dog switch. (BFM #3 b13 = 1)

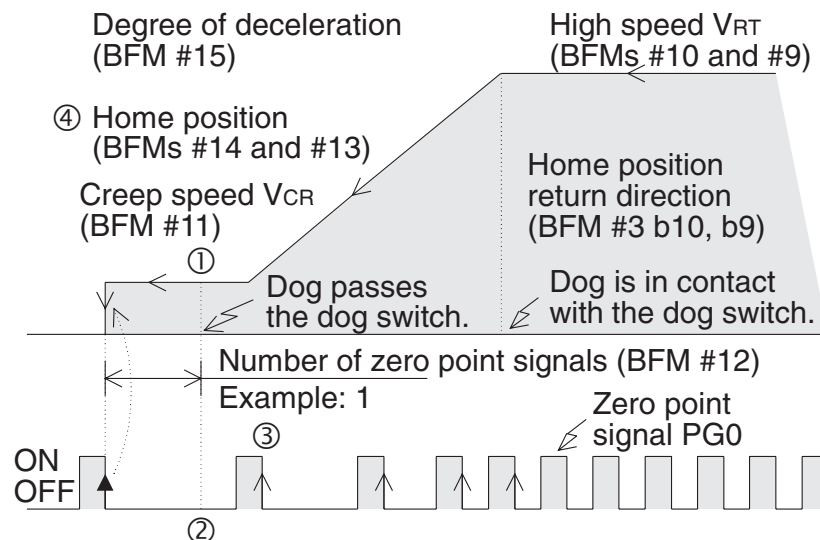

- ① With this method, the length L of the dog is required to be determined so that deceleration is completed until the dog has passed the dog switch.
- ② Dispersion in the point at which the dog switch becomes unactuated while the dog is passing the dog switch is required to be adjusted so that the dog switch is actuated within the interval between two PG0 signals at any time.

(The actuation start point is not required to be adjusted.)

- ③ BFM #12 determines how many zero point signals PG0 should be counted after the dog has passed the dog switch. With this method, set the BFM #12 always to 1 so that the motor is stopped at the first zero point signal PG0.
  - ④ When the operation is stopped, the deviation counter clear signal CLR of the servo amplifier is output. The home position (BFMs #14 and #13) value is transferred to the current position (BFMs #27 and #26), and the home position return completed flag (BFM #28 b2) is set to 1.
- It may be required to perform a home return operation after the dog has passed the dog switch. In such a case, the dog should be preliminarily moved back to a position before the dog switch by the jog operation before the home position return operation is performed again. This procedure may be automatically performed when the limit switches for detecting the forward and reverse limits are connected to the PC. (See Section 6.1.4.)

### 6.1.3 Undershoot Detection Home Return Positioning Method

#### < Undershoot detection home return positioning method >

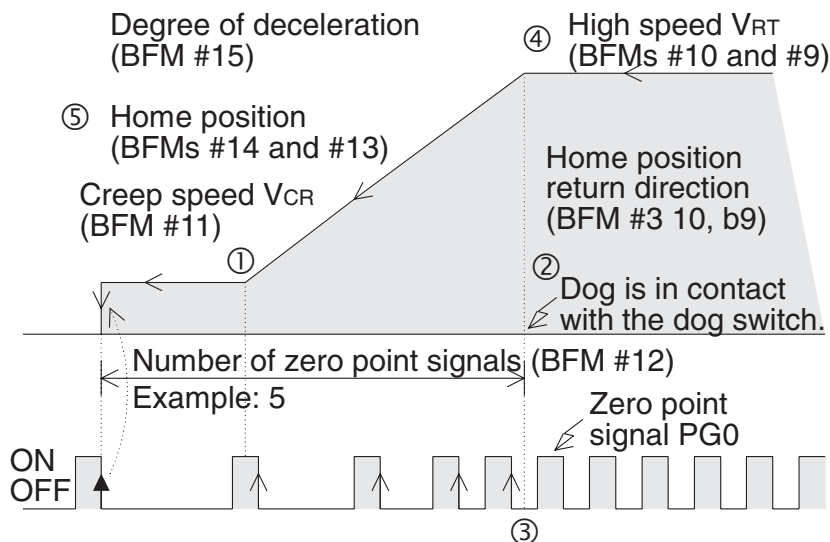

- With this method, the motor starts deceleration when the dog is in contact with the dog switch, and the motor is stopped immediately when the specified number of zero point signals PG0 are received and the speed becomes sufficiently slow. (BFM #3 b13 = 0)
- ① With this method, the number of zero point signals is required to be set so that deceleration is completed before the stop point.
- ② Set the length L of the dog long enough so that the dog switch continues to be actuated even when the dog is at the stop point. This allows the dog automatically go back and reproach the dog switch before the home position return operation is performed again consecutively.

But even if the dog is short, when the limit switches for detecting the forward and reverse limits are connected to the PC, the dog switch can automatically go back using these limit switches. (See Section 6.1.4.)

- ③ Dispersion in the point at which the dog starts to be in contact with the dog switch is required to be adjusted so that the dog switch is actuated within the interval between two PG0 signals at any time.
- ④ Set the home position return speed  $V_{RT}$  as small a value as possible because there may be a response lag with the dog switch. It is recommended to set a  $V_{CR}$  value small enough compared with the  $V_{RT}$  value so that the stop precision is improved.
- ⑤ When the operation is stopped, the error counter clear signal CLR of the servo amplifier is output. The home position (BFMs #14 and #13) value is transferred to the current position (BFMs #27 and #26), and the home position return completed flag (BFM #28 b2) is set to 1.

### 6.1.4 Home Position Return Operation

#### < Home position return operation >

The home position return operation varies depending on the start position.

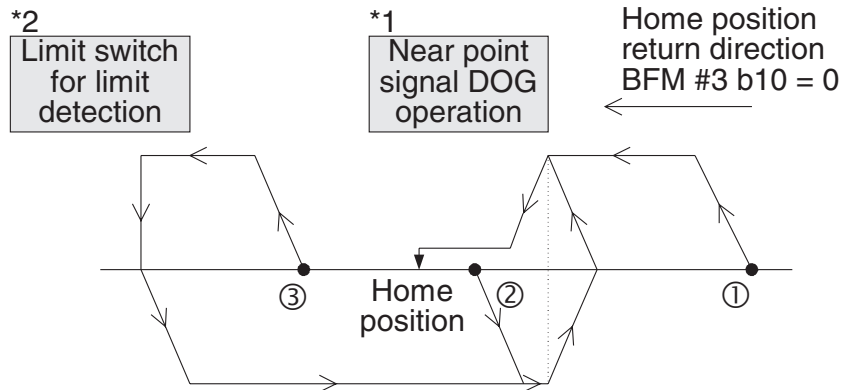

- ① The near point signal is turned off (before the DOG passes).
- ② The near point signal is turned on.
- ③ The near point signal is turned off (after the DOG has passed).

For this operation, the limit switches for detecting the forward limit and the reverse limit should be provided on the PC.

When the limit switch for limit detection is actuated, the home position return operation is not performed even if the home position return operation is started. Move the dog by performing the JOG operation so that the limit switch for limit detection is not actuated, then start the home position return operation.

- \*1 The example above shows the case where the BFM #3 b12 is set to 0 (DOG input polarity OFF → ON).
- \*2 When the limit switch for limit detection is turned on, the pulse output is immediately stopped (BFM #25 b3: ON). At this time, the clear signal is also output.

#### < When the stepper motor is used >

When the stepper motor is used, rigid attention should be paid to the following items.

- ① If the motor capacity is not sufficient compared with the load torque, the motor may stall. In such a case, even if the specified quantity of pulses are supplied to the motor, the expected drive quantity may not be obtained.
- ② Start and stop the motor slowly enough (by setting a long acceleration/deceleration time to the BFM #15) so that the acceleration/deceleration torque does not become excessive.
- ③ A resonance point is present in low speed operation. It is recommended to avoid this point. Set the bias speed (BFM #6), and do not perform operation at a speed slower than that.
- ④ An external power supply may be required for signal communication with the drive amplifier.

## 6.2 Single-Speed Positioning Operation and Interrupt Single-Speed Positioning Operation

### ■ Single-speed positioning operation

When the single-speed positioning operation command is received, the motor performs the following operation.

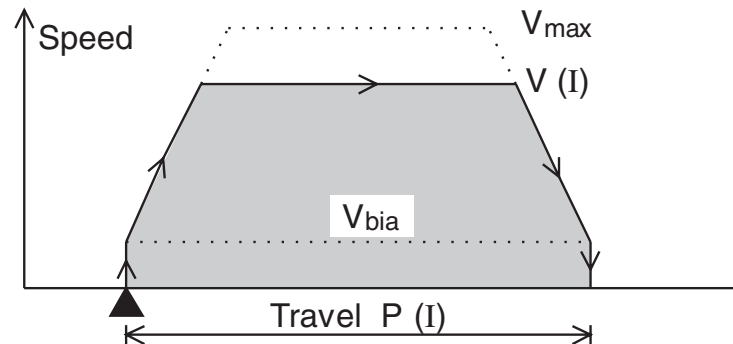

When the start command is given, the motor accelerates up to the operating speed  $V(I)$  (BFMs #20 and #19), then decelerates and stops in the set position  $P(I)$  (BFMs #18 and #17).

The absolute position from the point at which the current position  $CP$  becomes 0 (electric home position) or the relative position from the start position can be specified as the set position. When a servo motor is used,  $V_{bia}$  is generally set to 0.

### ■ Interrupt single-speed positioning operation

When the interrupt single-speed positioning operation command is received, the motor performs the following operation.

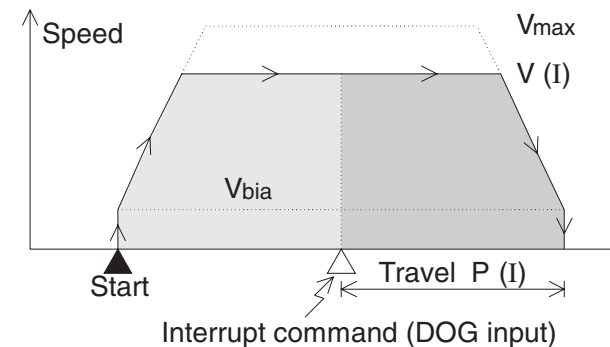

The interrupt command is connected to the DOG input in the PGU.

When the start command is received, the motor starts operation. When the INTERRUPT input is received, the motor moves by the specified distance, then stops (The relative travel exclusively can be specified.)

The current value is cleared by the start command. The current value starts to change by the INTERRUPT input, and becomes equivalent to the set position when the operation is completed.

Accordingly, rigid attention should be paid when operations using absolute position specification are performed also.

The interrupt command detects change in the input signal. (OFF→ON, ON→OFF)

### 6.3 Two-Speed Positioning Operation and External Command Positioning Operation

#### ■ Two-speed positioning operation

The motor performs the following operation by the two-speed positioning operation command. Approach at high speed as well as processing and moving forward at low speed can be performed.

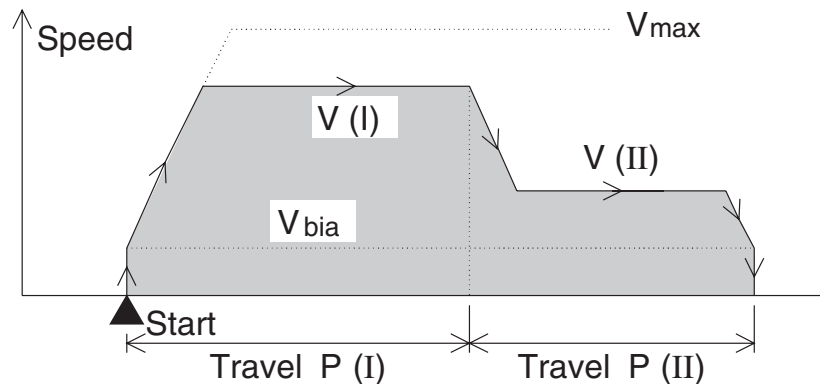

When the start command is received, the motor performs positioning at the operating speed  $V(I)$  (BFMs #20 and #19) until the set position  $P(I)$  (BFMs #18 and #17), then at the operating speed  $V(II)$  (BFMs #24 and #23) until the set position  $P(II)$  (BFMs #22 and #21) (two-step speed).

#### ■ External command positioning operation

Commands for determining the deceleration start point and the stop point are given from the external limit switches. The PGU does not control the pulse quantity, and positioning is performed by the two-step speed technique.

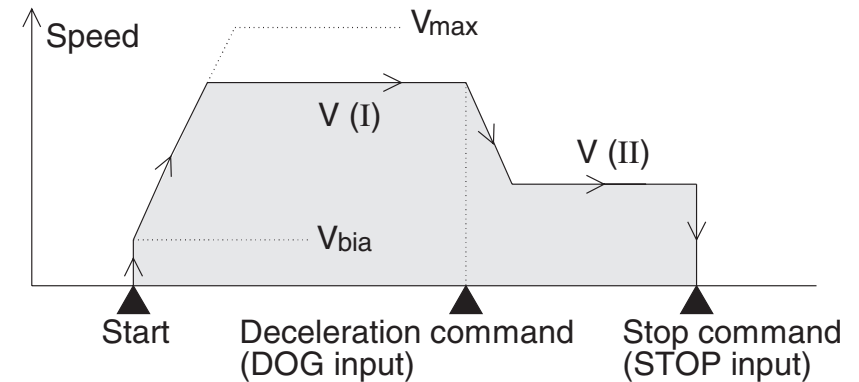

When the start command is received, the motor performs positioning at the operating speed  $V(I)$  (BFMs #20 and #19) until the deceleration command is received. At that time, the motor decelerates to the operating speed  $V(II)$  (BFMs #24 and #23). When the stop command is received, pulse generation is stopped immediately.

The rotation direction is determined by the sign (positive or negative) of the operating speed  $V(I)$ .

The deceleration command detects the change in the input signal. (OFF→ON, ON→OFF)

The stop command reads the state of the input signal level. (OFF or ON)

The sign of operating speed  $V(II)$  is disregarded.

## 6.4 Variable Speed Operation

### ■ Variable speed operation

- When the operation command BFM #25 b12 is set to 1, the speed pulses specified in the BFMs (#20 and #19) are generated.
- This operating speed can be freely changed even while pulses are generated. However, because there is no cushion start/stop function, acceleration and deceleration must be controlled by the PC.
- Only b0 (error reset) and b12 (variable speed operation) of the operation command BFM #25 are valid in this mode. Set b1 to b11 to 0.  
When b12 is set to 1, variable speed operation is performed.  
When b12 is set to 0, pulse output is stopped.  
(The pulse output does not stop even if "0" is written in BFM #20, #19.)
- As for the parameter BFM #3, only b1 and b0 (system of units) and b8 (pulse output format) are valid.
- The rotation direction (forward or reverse) can be specified by the sign (positive or negative) of the speed command (BFMs #20 and #19).

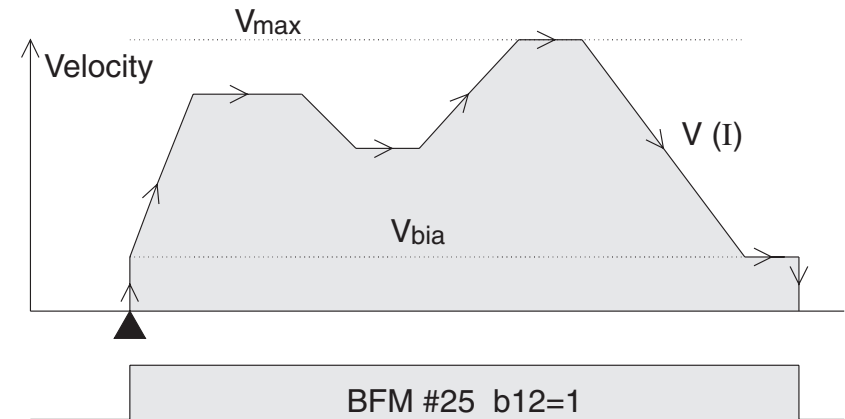

- Do according to the undermentioned procedure when you change the direction of the rotation.
  - ① Turn OFF b12 of BFM #25.
  - ② Change the value at drive speed (BFM #20, BFM #19).  
(The direction of the rotation is decided according to the sign)
  - ③ Again, turn ON b12 of BFM #25.

## 6.5 Common Matter for Operation Modes

### < Handling the stop command >

In all operation modes, the stop command is valid at any time during operation. However, if a stop command is received during a positioning operation, the motor decelerates and stops. And after restarting, the motor normally travels by the remaining distance and then stops. (The motor can be stopped and the operation can be completed without traveling the remaining distance. Refer to 5.2)

### < Duplicated specifications for various operation modes >

When the bits which determine operation modes such as b4 to b6 and b8 to b12 are turned on simultaneously in the operation command BFM #25, any operation is not executed.

If an other mode input is turned on while operation is being performed in any mode, such an input is neglected.

### < When travel time is small >

When the travel time is small compared to the acceleration / deceleration time ( $T_a$ ), the motor cannot realize specified speed.

#### ● Single-speed positioning operation

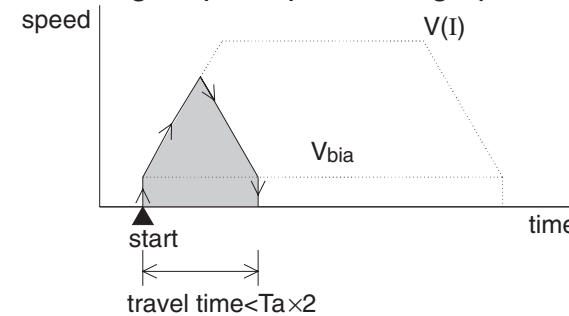

#### ● Interrupt single operation

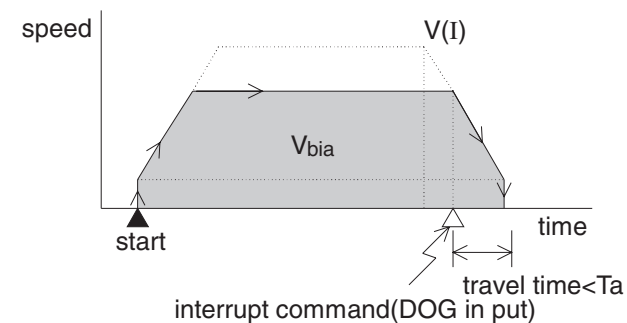

#### ● Two-speed positioning operation

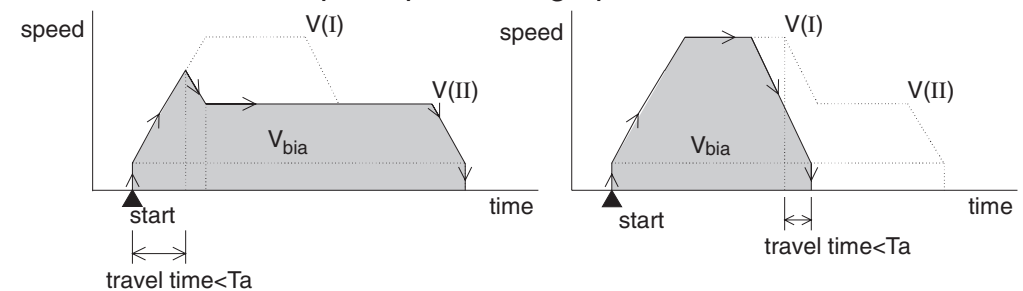



### 6.6 Connection of DOG and STOP Inputs and Handling of Limit Switches for Limit Detection

Various limit switch inputs are connected to the DOG input and the STOP input in accordance with the operation mode.

The polarity of these limit switch inputs is inverted by the state of the BFM #3 b12 and b14. (Refer to 5.2)

Connection examples are shown below.

- ① Home position return operation mode (BFM #25 b6 = 0 → 1)

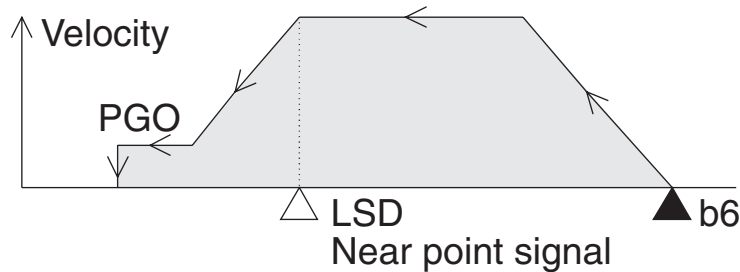

- ② Interrupt single-speed operation mode (BFM #25 b9 = 0 → 1)

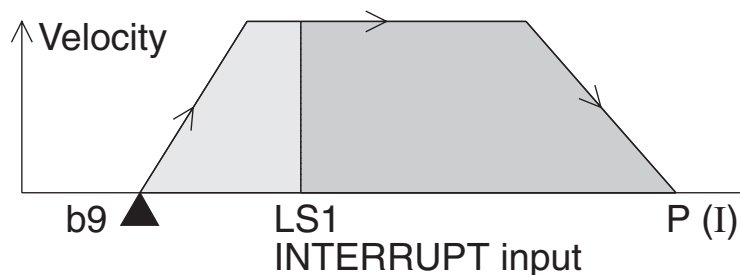

- ③ External command operation mode (BFM #25 b11 = 0 → 1)

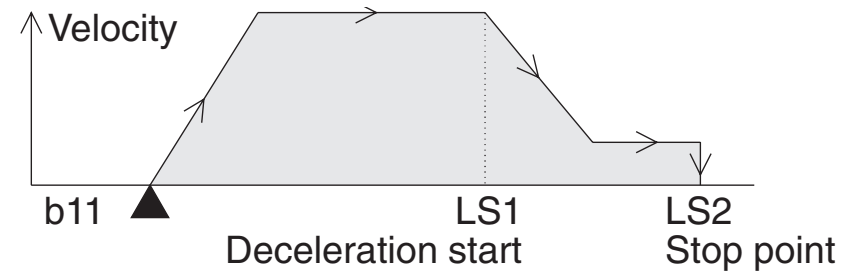

**< When normally open contacts are used >**

The input connection diagram shown below indicates the case where the BFM #3 b 12 and b14 are set to 0 and normally open contacts (a-contacts) are used.

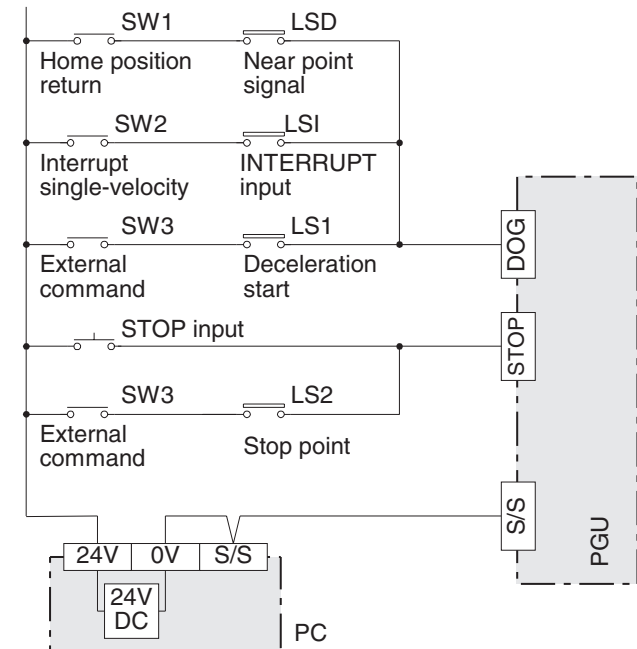

Input switches SW1 to SW3 are selected in accordance with the type of operation.

### < When normally closed contacts are used >

The input connection diagram shown below indicates the case where the BFM #3 b 12 and b14 are set to 1 and normally closed contacts (b-contacts) are used.

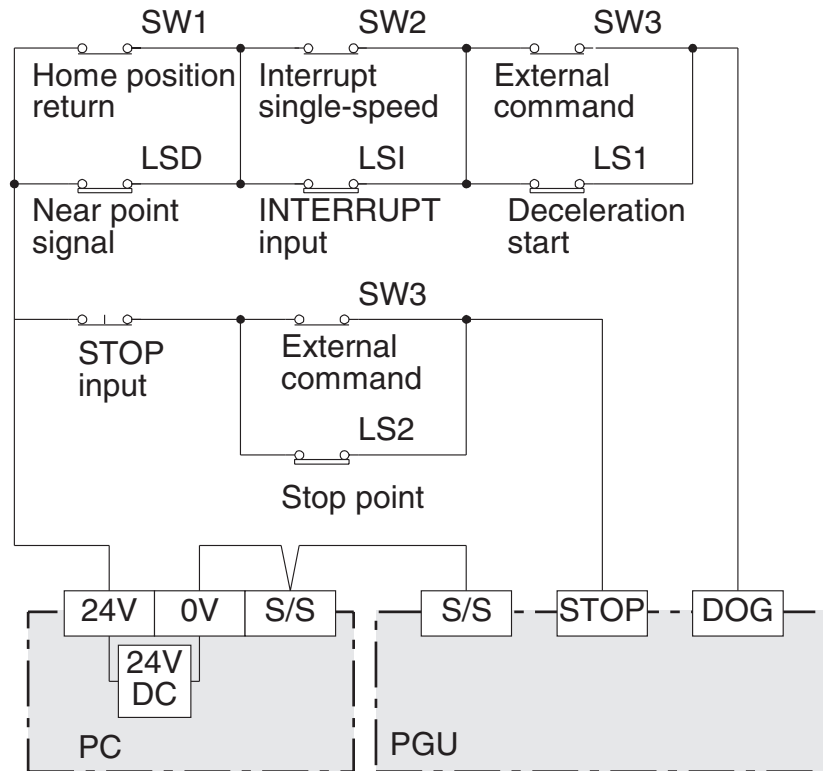

Input switches SW1 to SW3 are selected in accordance with the type of operation.

- To assure safety, provide limit switches for detecting the forward and reverse limits on the servo amplifier also. (See Section 8.4.) Make sure so that the limit switches on the PC are actuated simultaneously with or a little earlier than the limit switches on the servo amplifier.

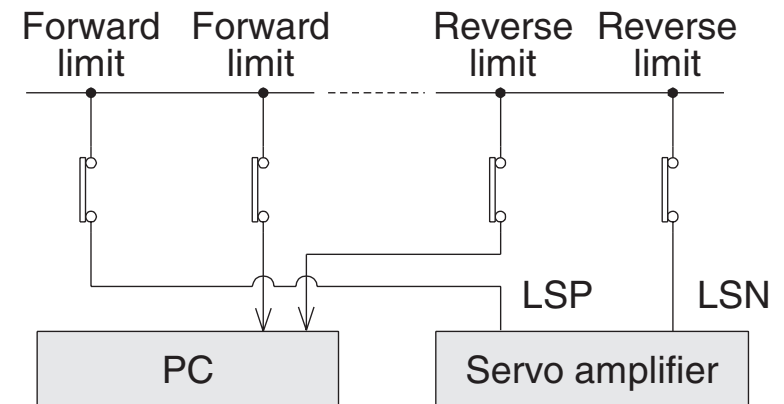

- Because a drive amplifier for a stepper motor does not have these terminals, make sure to provide limit switches on the PC.
- When b2 and b3 of the BFM #25 are driven by these signals, pulse output is immediately stopped and the counter clear output CLR is generated. (See Section 8.4.)
- Evade from the state of the pulse output stop by Jog in the opposite direction when forward pulse stop (BFM #25 b2) or reverse pulse stop (BFM #25 b3) is turned on.
- Because the counter clear output CLR is generated, the forward pulse stop and the reverse pulse stop cannot be used as a stop and home position.

## 6.7 Various Operation Modes and Buffer Memory Setting

< Various operation modes and buffer memory setting >

O indicates the item required to be set.

| BFM No.     |            | Name  | JOG  | Home position return | Single-speed positioning | Interrupt single-speed positioning | Two-speed positioning | External command positioning | Variable speed |
|-------------|------------|---|--|----------------------|--------------------------|------------------------------------|-----------------------|------------------------------|----------------|
| Higher bits | Lower bits |   |  |                      |                          |                                    |                       |                              |                |
| —           | #0         | Pulse rate  | Not required to be set for motor system of units (PLS and Hz). |                      |                          |                                    |                       |                              |                |
| #2          | #1         | Feedrate  | Required to be set for machine and combined systems of units.  |                      |                          |                                    |                       |                              |                |
| —           | #3         | Parameter   | O  | O                    | O                        | O                                  | O                     | O                            | O              |
| #5          | #4         | Maximum speed   | O  | O                    | O                        | O                                  | O                     | O                            | O              |
| —           | #6         | Bias speed *1   | O  | O                    | O                        | O                                  | O                     | O                            | O              |
| #8          | #7         | JOG speed   | O  | —                    | —                        | —                                  | —                     | —                            | —              |
| #10         | #9         | Home position return speed (high speed)               | —  | O                    | —                        | —                                  | —                     | —                            | —              |
| —           | #11        | Home position return speed (creep speed)              |  |                      |                          |                                    |                       |                              |                |
| —           | #12        | Number of zero point signals for home position return |  |                      |                          |                                    |                       |                              |                |
| #14         | #13        | Home position   | —  | —                    | —                        | —                                  | —                     | —                            | —              |
| —           | #15        | Acceleration/deceleration time                        | O  | O                    | O                        | O                                  | O                     | O                            | —              |
| —           | #16        | Reserved  | —  | —                    | —                        | —                                  | —                     | —                            | —              |
| #18         | #17        | Set position (I)                                      | —  | —                    | O                        | O                                  | O                     | —                            | —              |
| #20         | #19        | Operating position (I)                                | —  | —                    | O                        | O                                  | O                     | *3                           | *3             |
| #22         | #21        | Set position (II)                                     | —  | —                    | —                        | —                                  | O                     | —                            | —              |
| #24         | #23        | Operating velocity (II)                               | —  | —                    | —                        | —                                  | O                     | O                            | —              |
| —           | #25        | Operation command                                     | O  | O                    | O                        | O                                  | O                     | O                            | O              |
| #27         | #26        | Current position                                      | *2   | —                    | *2                       | *2                                 | *2                    | —                            | —              |
| —           | #28        | Status information                                    | *2   | *2                   | *2                       | *2                                 | *2                    | *2                           | *2             |
| —           | #29        | Error code  | *2   | *2                   | *2                       | *2                                 | *2                    | *2                           | *2             |
| —           | #30        | Model code  | *2   | *2                   | *2                       | *2                                 | *2                    | *2                           | *2             |
| —           | #31        | Reserved  | —  | —                    | —                        | —                                  | —                     | —                            | —              |

\*1 When a servo motor is used, the initial value 0 can be used.

\*2 Valid information

\*3 FP/RP output is generated by a positive/negative speed command. The absolute value shall be a value within the range between the bias speed (BFM #6) and the maximum speed (BFMs #5 and #4).

## 7. OUTLINE OF FROM/TO INSTRUCTION (PC)

### 7.1 FROM/TO Instruction

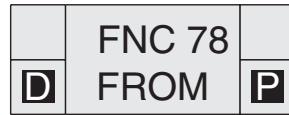

Reading from BFM

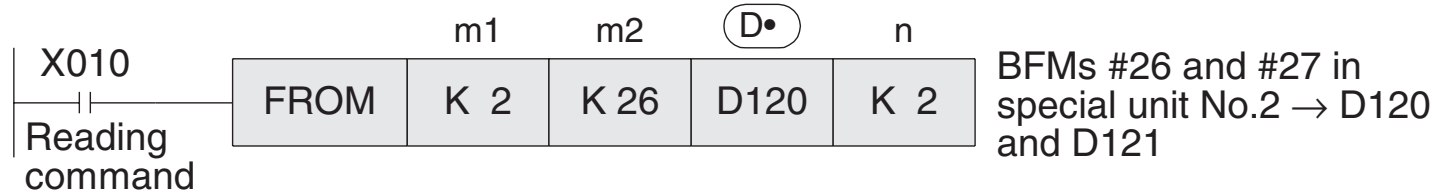

m1 : Special unit/block No. (K0 to K7 starting from the one nearest the basic unit)

m2 : Head address of buffer memory (m2 = K0 to K31)

**D•** : Head address of transfer destination

T, C, D, KnM, KnY, KnS, V and Z can be specified, and element No. can be coupled with an index.

n : Number of transfer points

(K1 to K32 for 16-bit instruction, and K1 to K16 for 32-bit instruction)

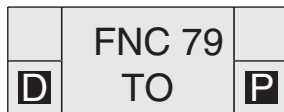

Writing to BFM

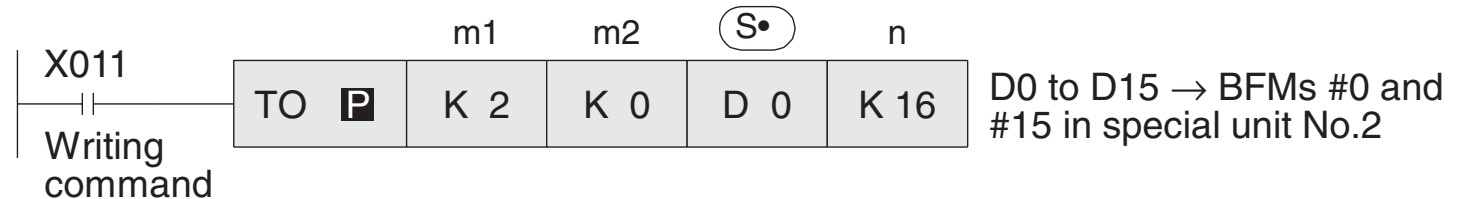

m1, m2, n : Same as above

**S•** : Head address of transfer destination

T, C, D, KnX, KnM, KnY, KnS, V, Z, K and H can be specified, and element No. can be coupled with an index.

- When X010 and X011 are turned off, transfer is not performed, and data in the transfer destination is not changed. For the details, refer to the programming manual of the PC main unit.

## 8. I/O SPECIFICATIONS

### 8.1 I/O Specifications

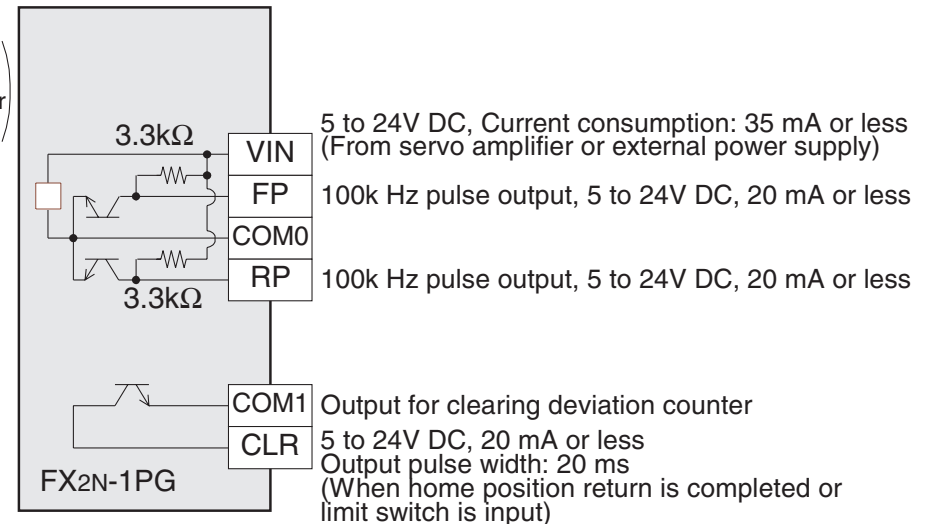
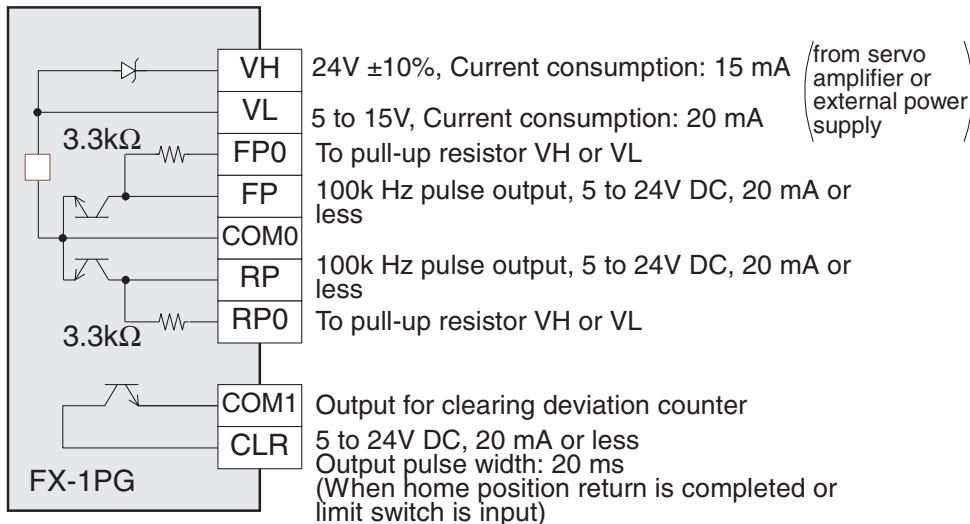
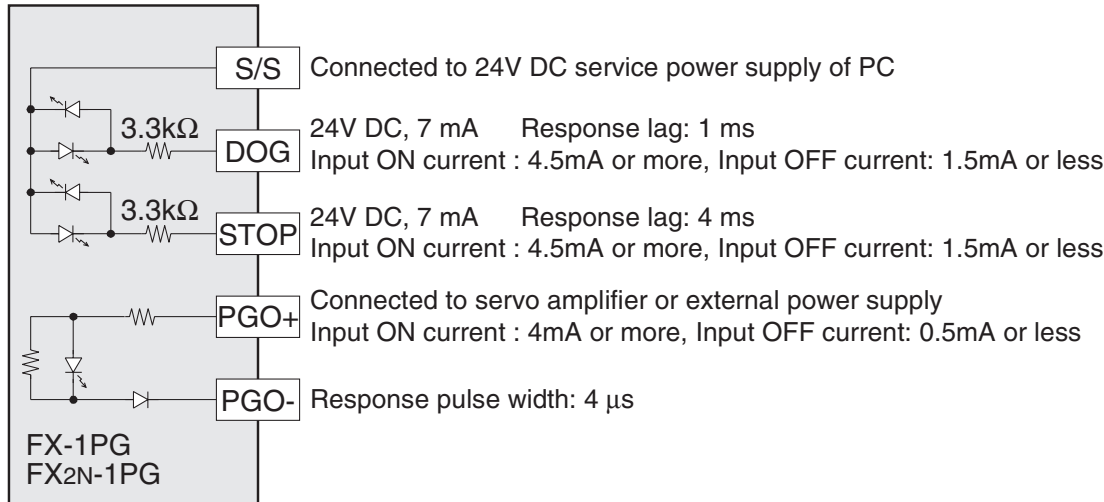

## 9. EXTERNAL CONNECTION EXAMPLES

### 9.1 Example of Connection Between FX-1PG and Stepper Motor

\*1: Connect either one in accordance with the external supply voltage. (See Section 8.1 Output Specifications.)

\*2: The number of counts of zero signals is adjusted to 0 when there is no home position sensor.  
At this time, when the dog input operates, the motor stops at once.  
Make the home position return speed low-speed very because it does not destroy the machine.

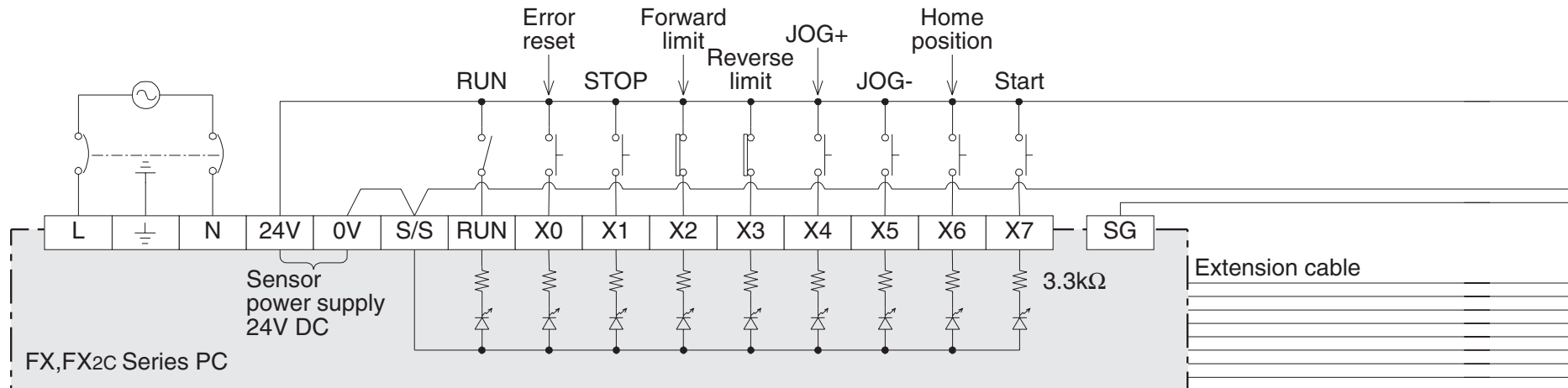

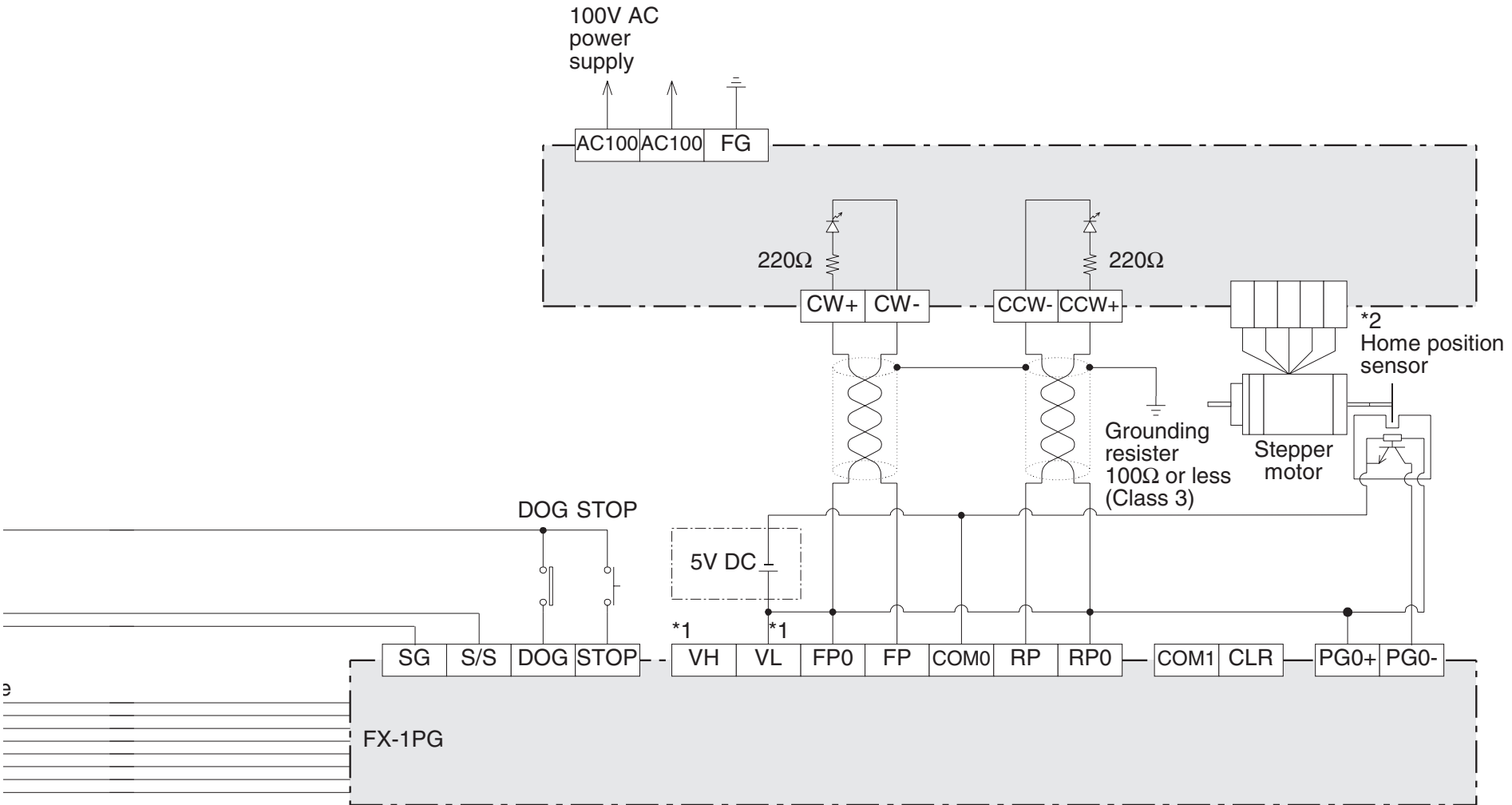

## 9.2 Example of Connection Between FX<sub>2N</sub>-1PG and Stepper Motor

\*1: The number of counts of zero signals is adjusted to 0 when there is no home position sensor.  
At this time, when the dog input operates, the motor stops at once.  
Make the home position return speed low-speed very because it does not destroy the machine.

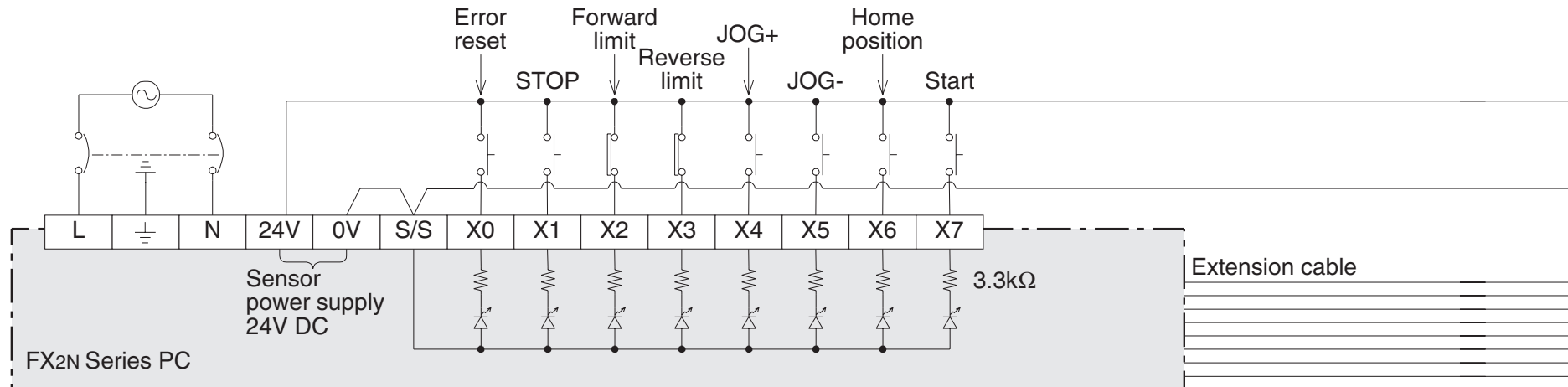



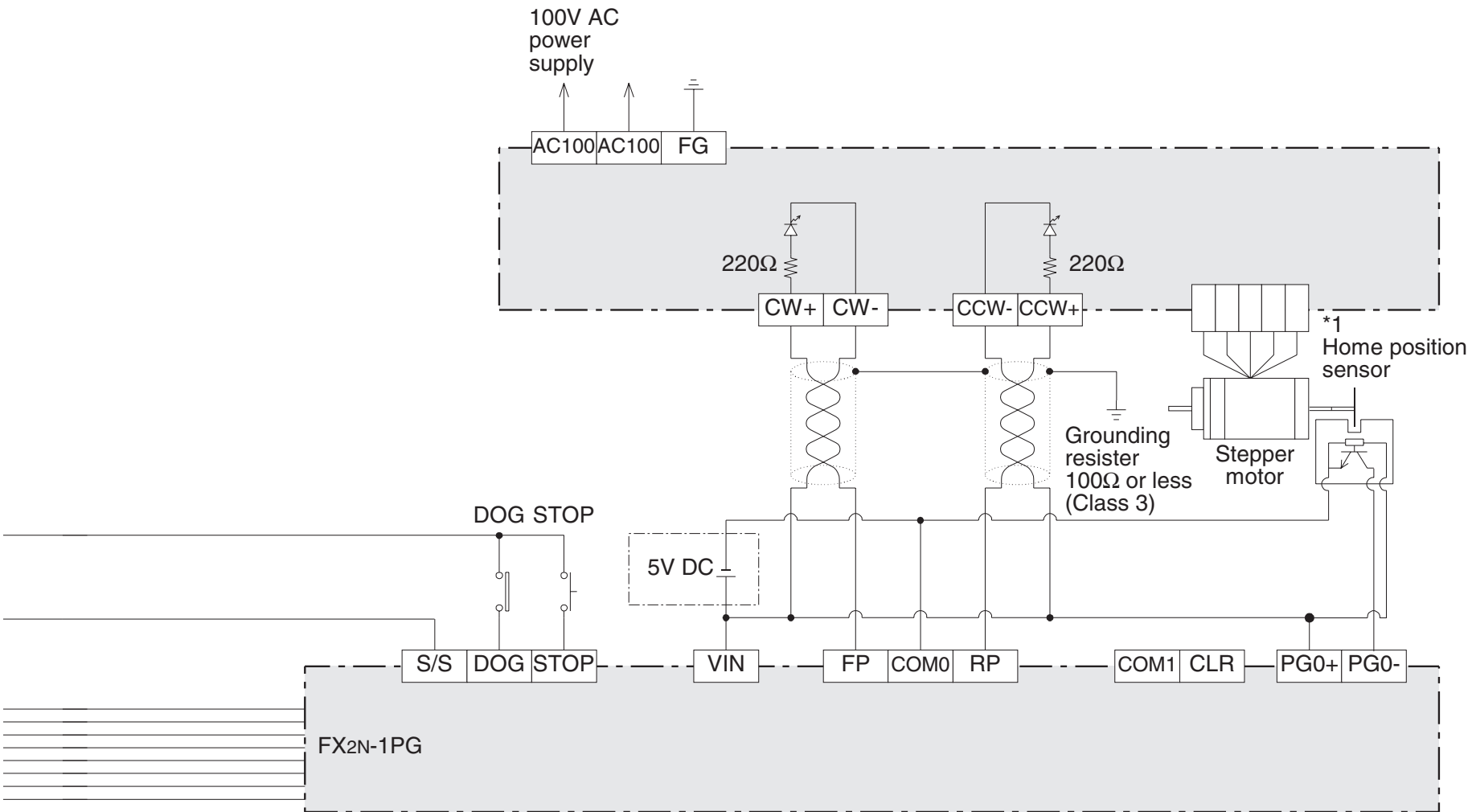

### 9.3 Example of External Connection (MR-C Servo Amplifier)

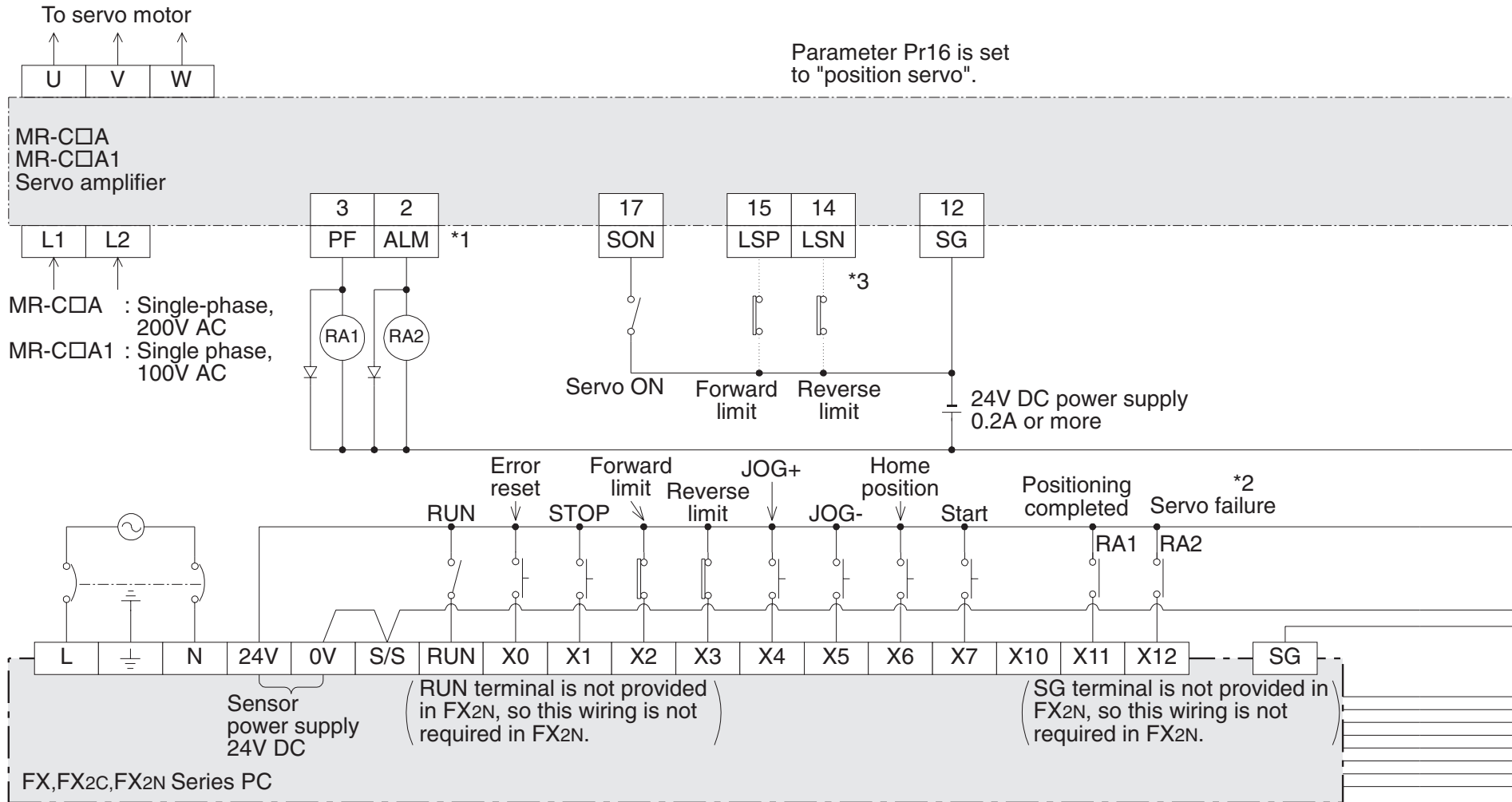

\*1 To release the alarm status, turn off the power, remove the cause of the alarm, then turn on the power again.

\*2 The failure (ALM) signal is turned on in the normal status. When an alarm has occurred (the ALM signal is turned off), stop pulse generation from the PGU using the program in the PC.

\*3 To assure safety, it is recommended to set the LSP and LSN signals to effective function parameters (using the parameter No. 6 in the MR-C servo amplifier).

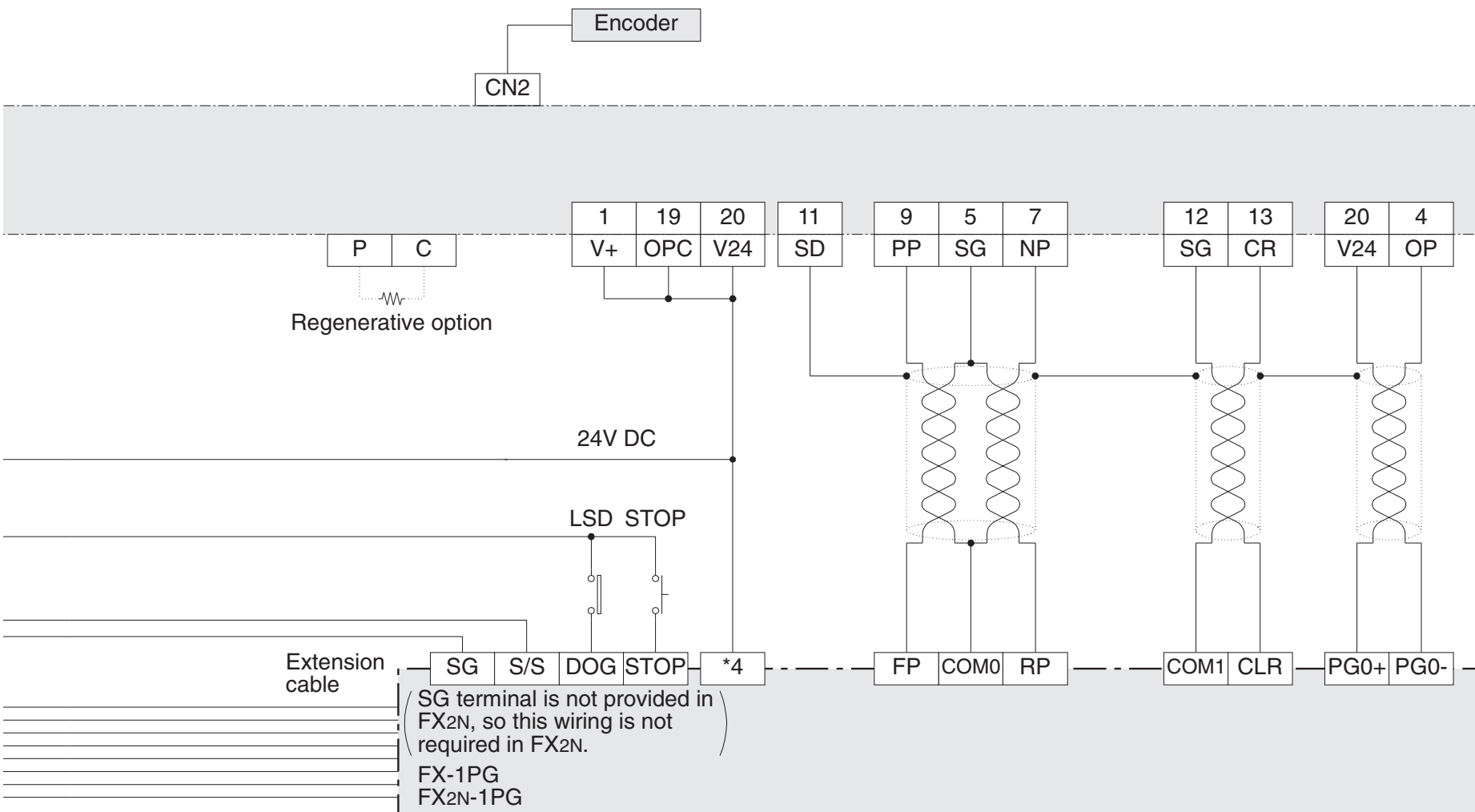

\*4 FX-1PG : Connect the VH terminal when the external power supply is 24V DC. Connect the VL terminal when the external power supply is 5V DC.  
 FX<sub>2N</sub>-1PG : Connect the VIN terminal.

9.4 Example of External Connection (MR-J Servo Amplifier)

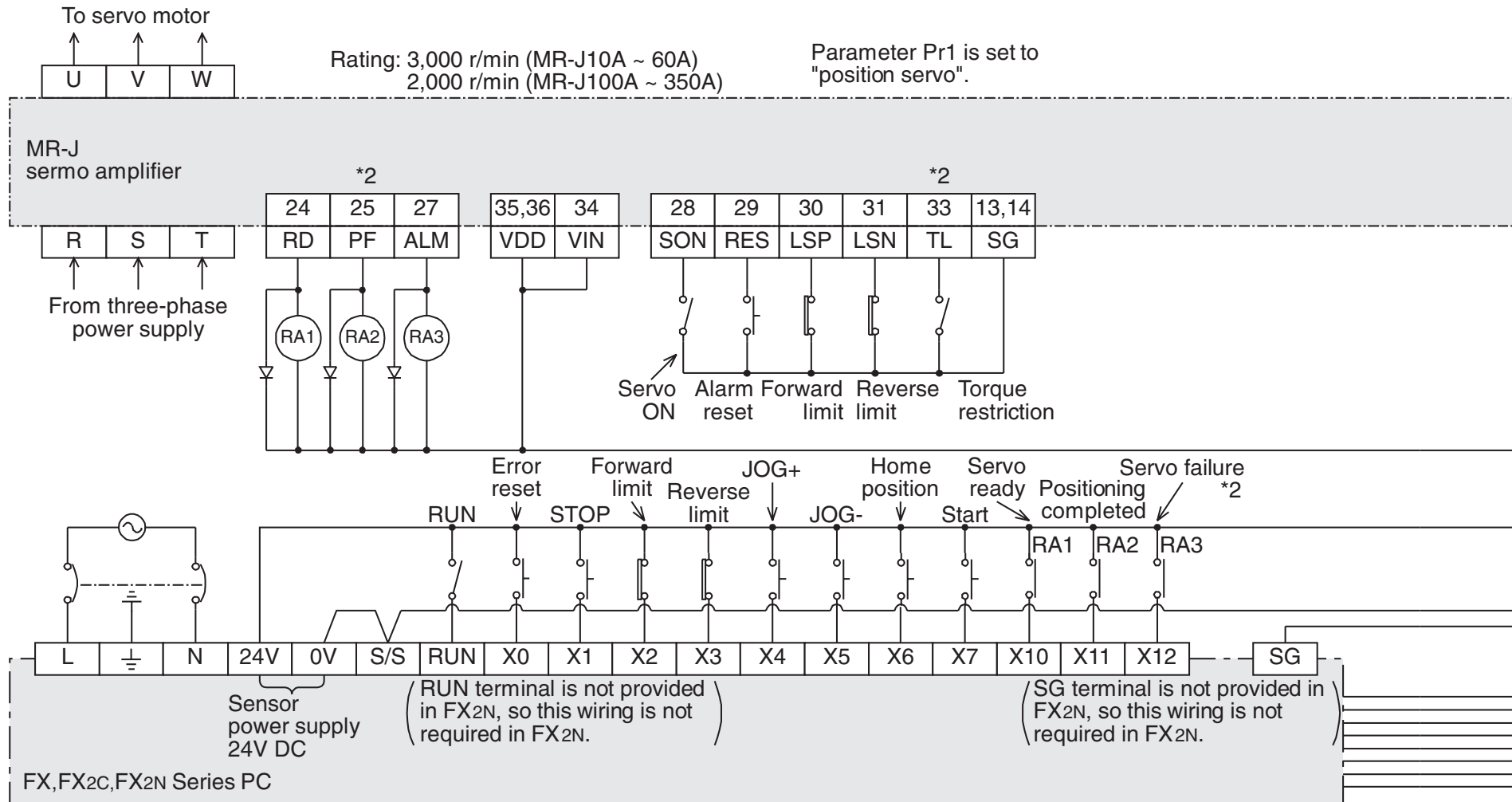

- \*1 FX-1PG: Connect the VH terminal when the power is supplied from the MR-J. Connect either the VH or VL terminal in accordance with the supply voltage when the power is supplied from an external power supply. (See Section 8.1.)  
FX<sub>2N</sub>-1PG: Connect the VIN terminal.
- \*2 Pin No. for the case where Pr9 of the servo amplifier is set to 042

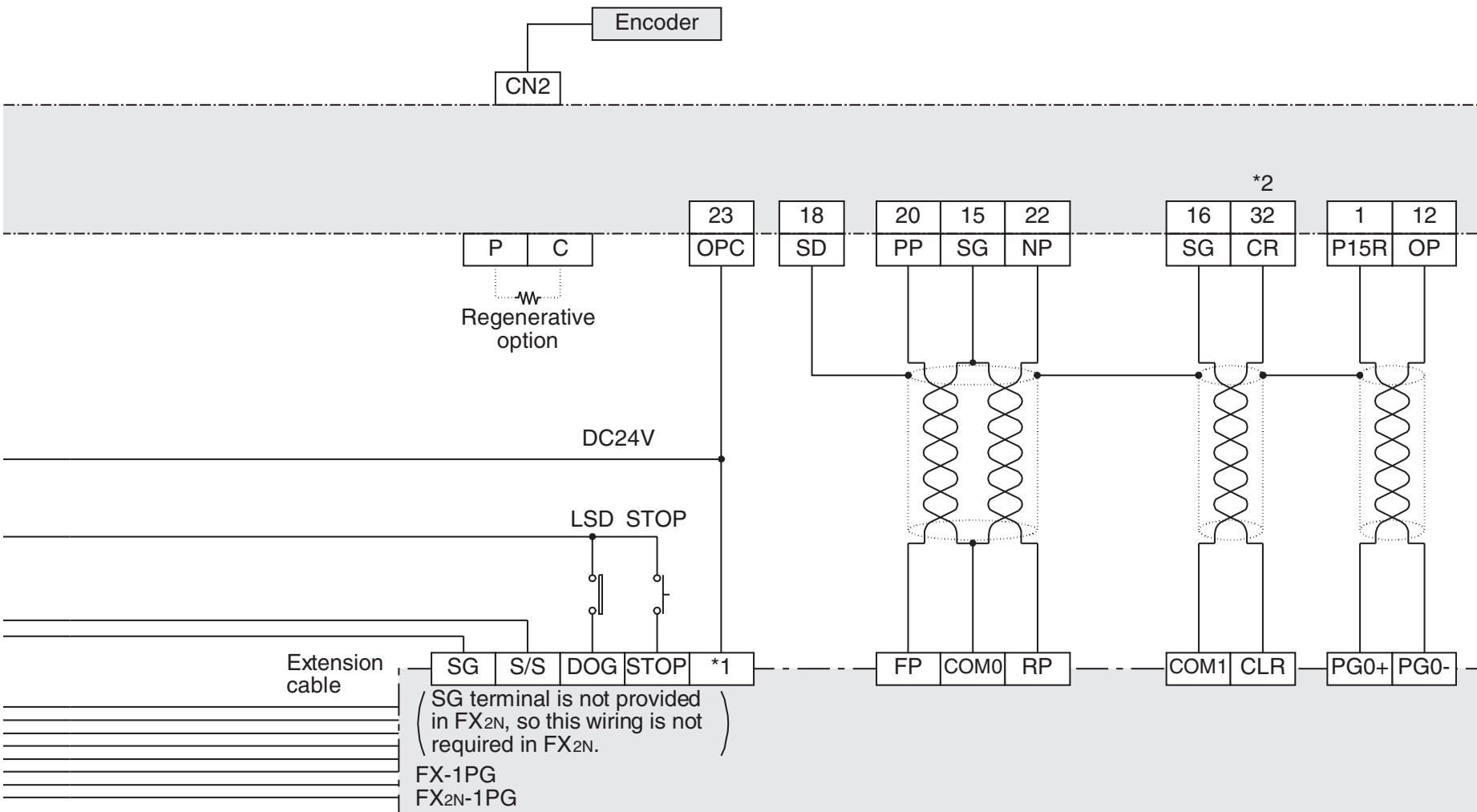

9.5 Example of External Connection (MR-J2 Servo Amplifier)

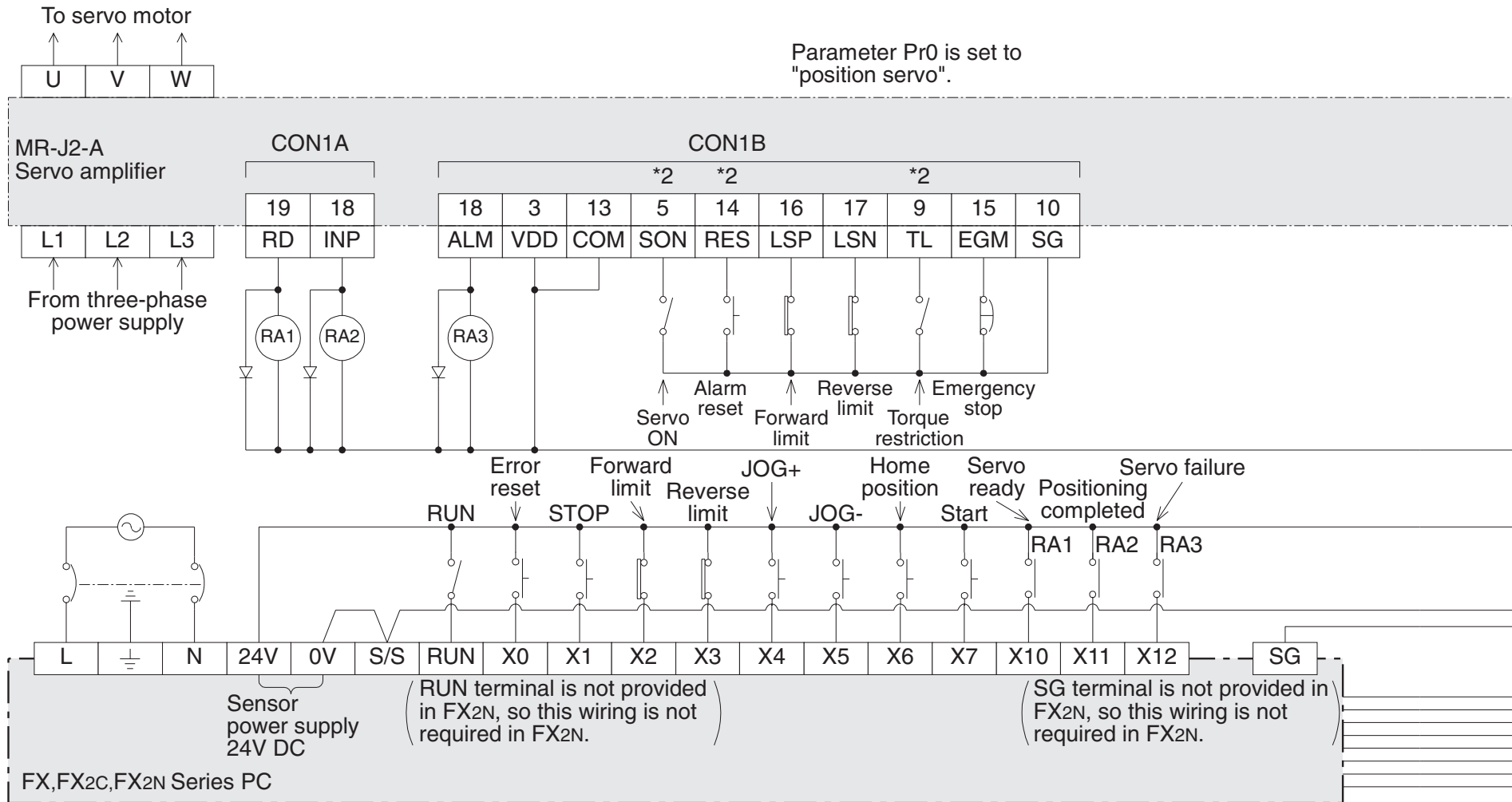

- \*1 FX-1PG: Connect the VH terminal when the power is supplied from the MR-J2. Connect either the VH or VL terminal in accordance with the supply voltage when the power is supplied from an external power supply. (See Section 8.1.)  
FX<sub>2N</sub>-1PG: Connect the VIN terminal.
- \*2 Pin No. can be modified using the extension parameter. (The example below shows the case where the initial value is set.)

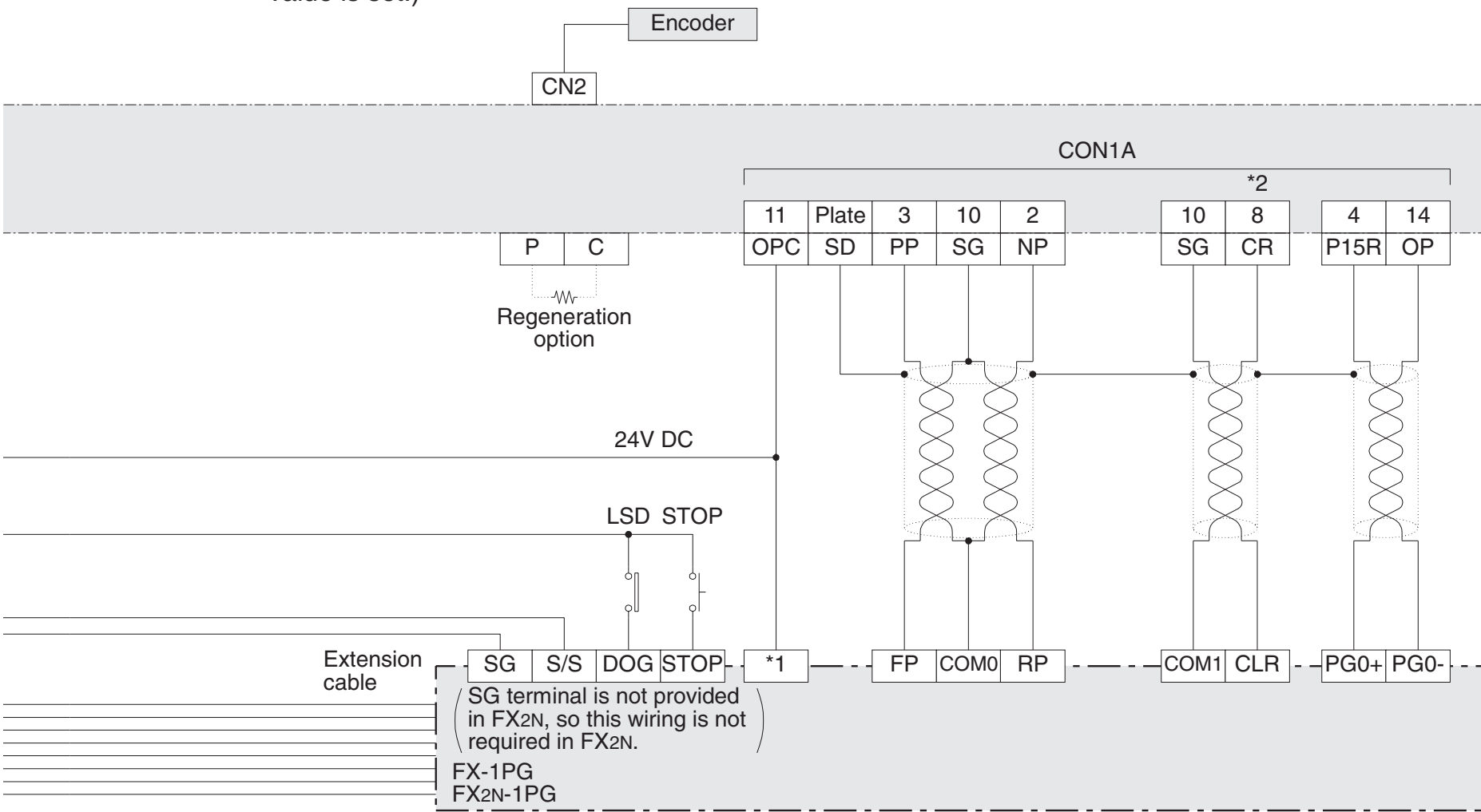

9.6 Example of External Connection (MR-H Servo Amplifier)

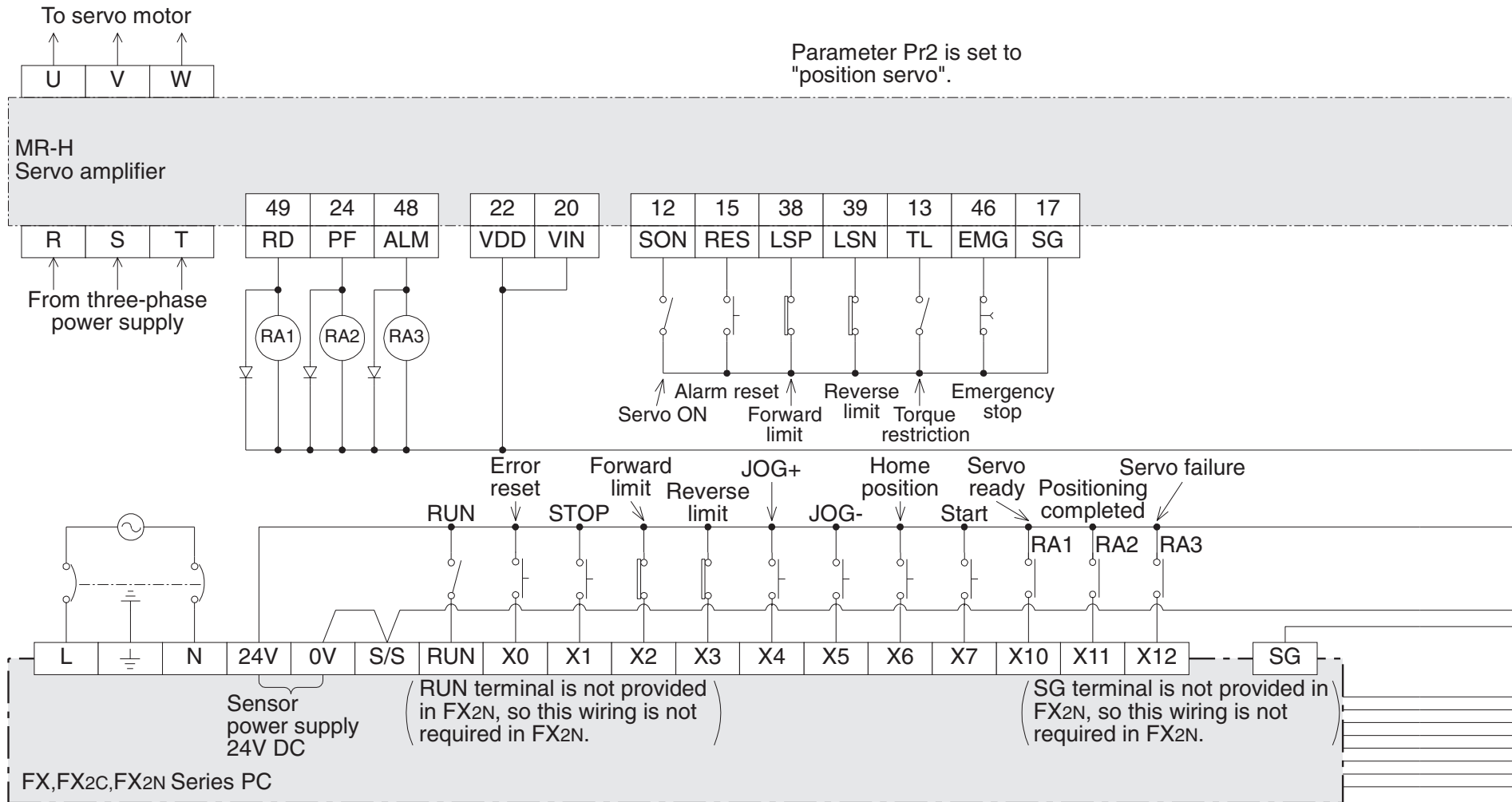



- \*1 FX-1PG: Connect the VH terminal when the power is supplied from the MR-H. Connect either the VH or VL terminal in accordance with the supply voltage when the power is supplied from an external power supply. (See Section 8.1.)  
FX<sub>2N</sub>-1PG: Connect the VIN terminal.

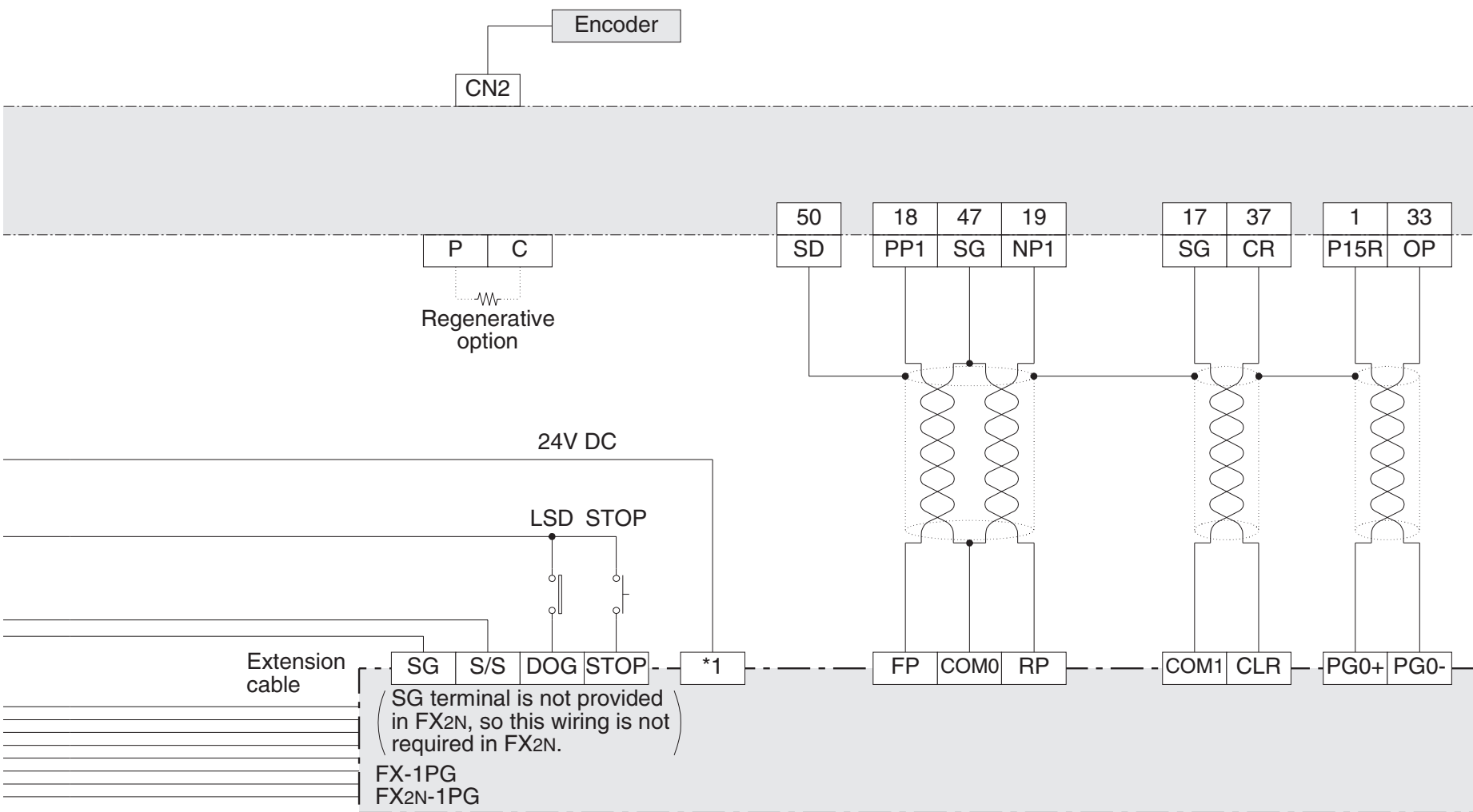

## 10. PROGRAM EXAMPLES

### 10.1 The reciprocation by single-speed positioning



Do not put the load on the motor for safety when you confirm the operation according to this program example.

<Outline of positioning>

1. The position of the motor moves to the machine home position according to the home position return start instruction now. (Machine home position return operation)  
At this time, the machine home position address is assumed to be "0".
2. While the forward or reverse button is pressed and held, the motor is driven forward or in reverse. (Jog operation)
3. The value of the motor advances 10000 mm according to the automatic drive start instruction. After wards, Y000 is turned on for two seconds as a stand by display stopping and at this time. Finally, the value of the motor retreats by 10000 mm. (Single-speed positioning operation)

Drive chart

1. Machine home position return operation

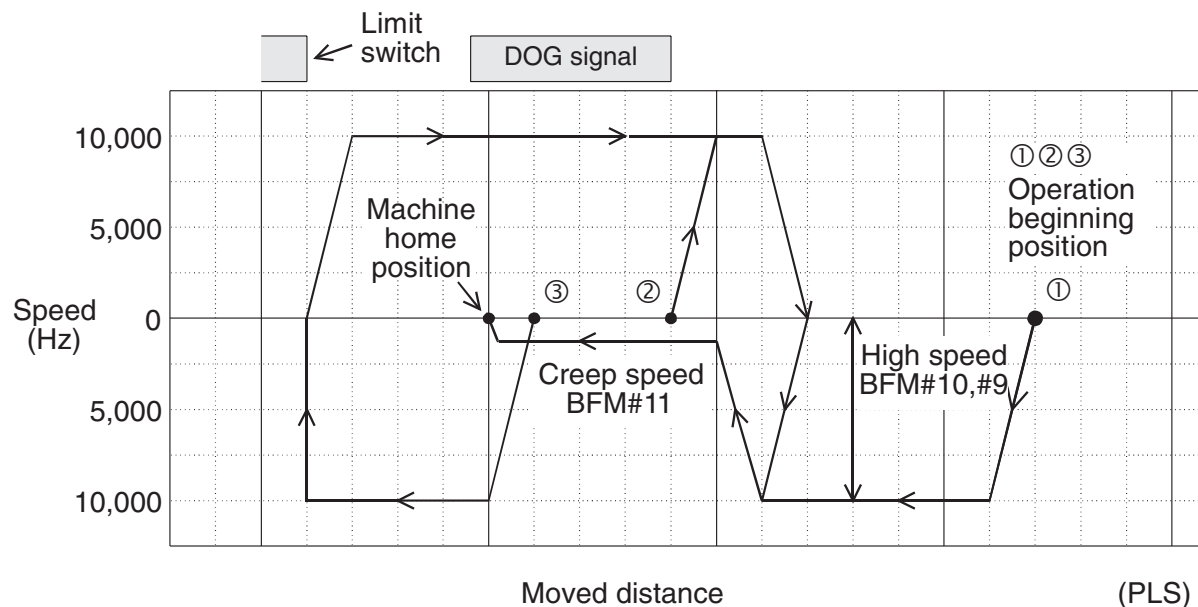

2. Jog operation

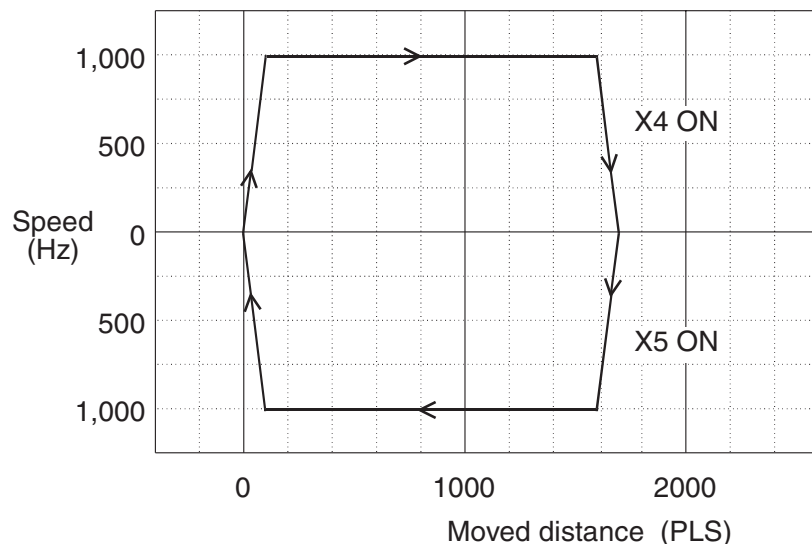

3. Single-speed positioning operation

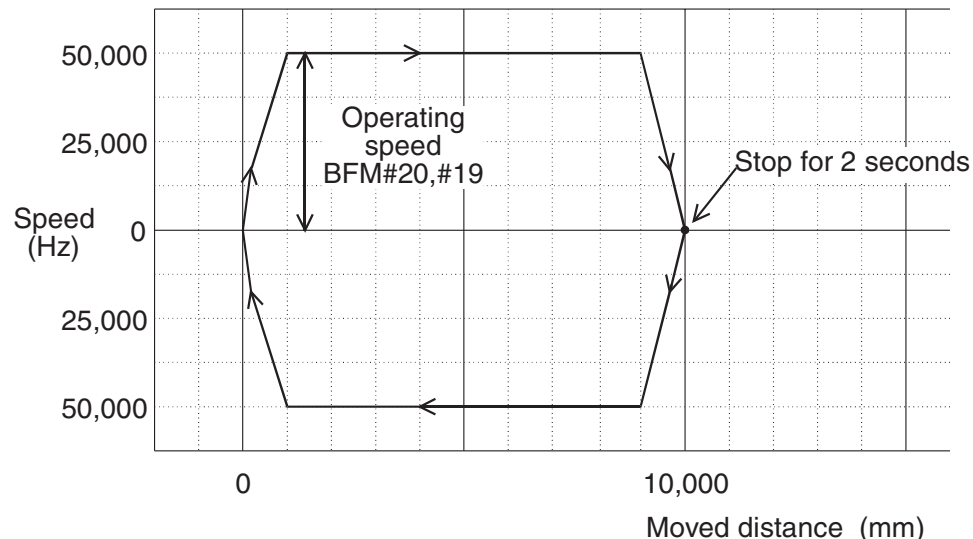

<I/O allocation>

| PLC (FX <sub>2</sub> , FX <sub>2C</sub> , FX <sub>2N</sub> , FX <sub>2NC</sub> ) |                        | PGU (FX-1PG, FX <sub>2N</sub> -1PG)   |
|--|------------------------|---|
| Input  | Output                 |   |
| X000: Error reset  | Y000: Stand by display | DOG: Near point signal input.   |
| X001: Stop command   |                        | STOP: Deceleration stop input.  |
| X002: Forward pulses stop  |                        | PGO: Z aspect pulses is input form the servo amplifier.                           |
| X003: Reverse pulses stop  |                        | FP: Forward pulses. Outputs to PP of the servo amplifier.                         |
| X004: Jog+ operation   |                        | RP: Reverse pulses. Outputs to NP of the servo amplifier.                         |
| X005: Jog- operation   |                        |   |
| X006: Home position return start   |                        |   |
| X007: Automatic drive start<br>(Single-speed positioning operation)              |                        | CLR: Output for clearing deviation counter. Outputs to CR of the servo amplifier. |

## &lt;Setting of buffer memory (BFM)&gt;

| BFM      | Item  | Set value                      | Note                         | BFM                        | Item                           | Set value                  | Note               |    |
|----------|---|--------------------------------|------------------------------|----------------------------|--------------------------------|----------------------------|--------------------|----|
| #0       | Pulse rate  | 8192 *1                        | PLS/REV                      | #16                        | –                              | –                          |                    |    |
| #2, #1   | Feed rate   | 1000                           | μm/REV                       | #18, #17                   | Set position (I)               | 10000                      | mm                 |    |
| #3       | Parameters  | b1:1, b0:0                     | Combined system              | #20, #19                   | Operating speed (I)            | 50000                      | Hz                 |    |
|          | b1, b0  |                                |                              | System of units            | #22, #21                       | Set position (II)          | –                  |    |
|          | b5, b4  | Position data multiplication   | b5:1, b4:1                   | 10 <sup>3</sup>            | #24, #23                       | Operating speed (II)       | –                  |    |
|          | b8  | Pulse output format            | 0                            | Forward pulse              | #25                            | Operation command          |                    |    |
|          | b9  | Rotation direction             | 0                            | The current value increase |                                | b0                         | Error reset        | M0 |
|          | b10   | Home position return direction | 0                            | The current value decrease |                                | b1                         | STOP               | M1 |
|          | b12   | DOG input polarity             | 0                            | DOG input ON               |                                | b2                         | Forward pulse stop | M2 |
|          | b13   | Count start timing             | 1                            | Rear end of DOG input      |                                | b3                         | Reverse pulse stop | M3 |
| b14      | STOP input polarity                                   | 0                              | Stops because of turning on  | b4                         |                                | JOG+                       | M4                 |    |
| b15      | STOP input mode                                       | 0                              | The remainder distance drive | b5                         |                                | JOG-                       | M5                 |    |
| #5, #4   | Maximum speed   | 50000                          |                              | b6                         |                                | Home position return start | M6                 |    |
| #6       | Bias speed  | 0                              |                              | b7                         | Address                        | b7=1 M7                    | Relative           |    |
| #8, #7   | JOG speed   | 10000                          |                              | b8~b12                     | Single speed positioning start | b8=M8<br>b12~b9<br>Unused  |                    |    |
| #10, #9  | Home position return speed (high speed)               | 10000                          |                              | #27, #26                   | Current position               | D11, D10                   | mm                 |    |
| #11      | Home position return speed (creep speed)              | 1500                           |                              | #28                        | Status                         | M31~M20                    |                    |    |
| #12      | Number of zero point signals for home position return | 10                             |                              | #29                        | Error code                     | D20                        |                    |    |
| #14, #13 | Home position   | 0                              |                              | #30                        | Model code                     | D12                        |                    |    |
| #15      | Acceleration / deceleration time                      | 100                            | ms                           | #31                        | –                              | –                          |                    |    |

\*1: This example is described as an example of servo mode by Mitsubishi Electric Corporation amplifier MR-J2.  
The value is different according to the connected servo amplifier.

The servo amplifier does the following setting according to the parameter.

Control mode: Position control

Electronic gear: CMX / CDV = 1/1

Specified pulse selection: Forward reverse pulse, Negative-true logic

Set other items according to the usage.

&lt;PC PROGRAM&gt;

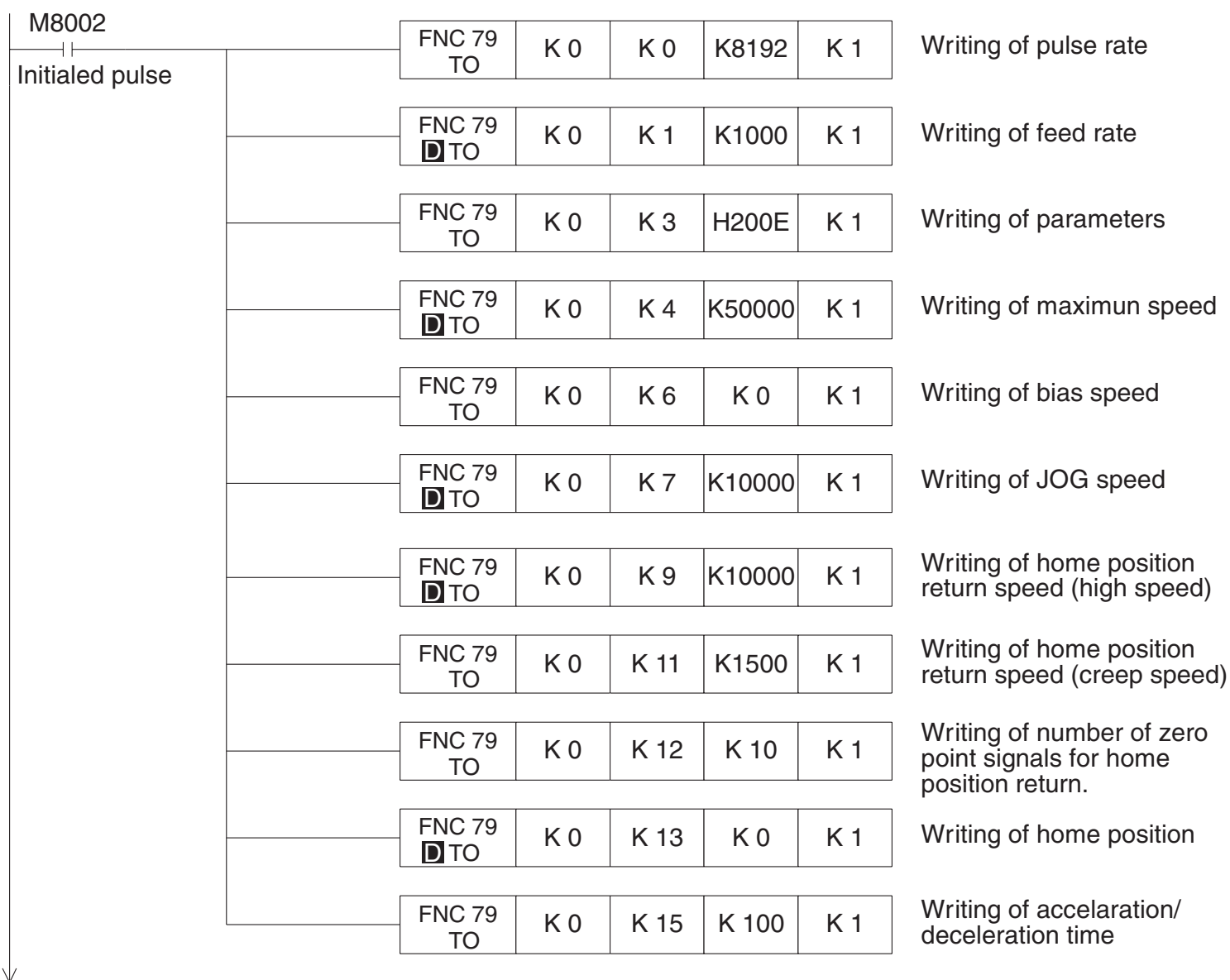

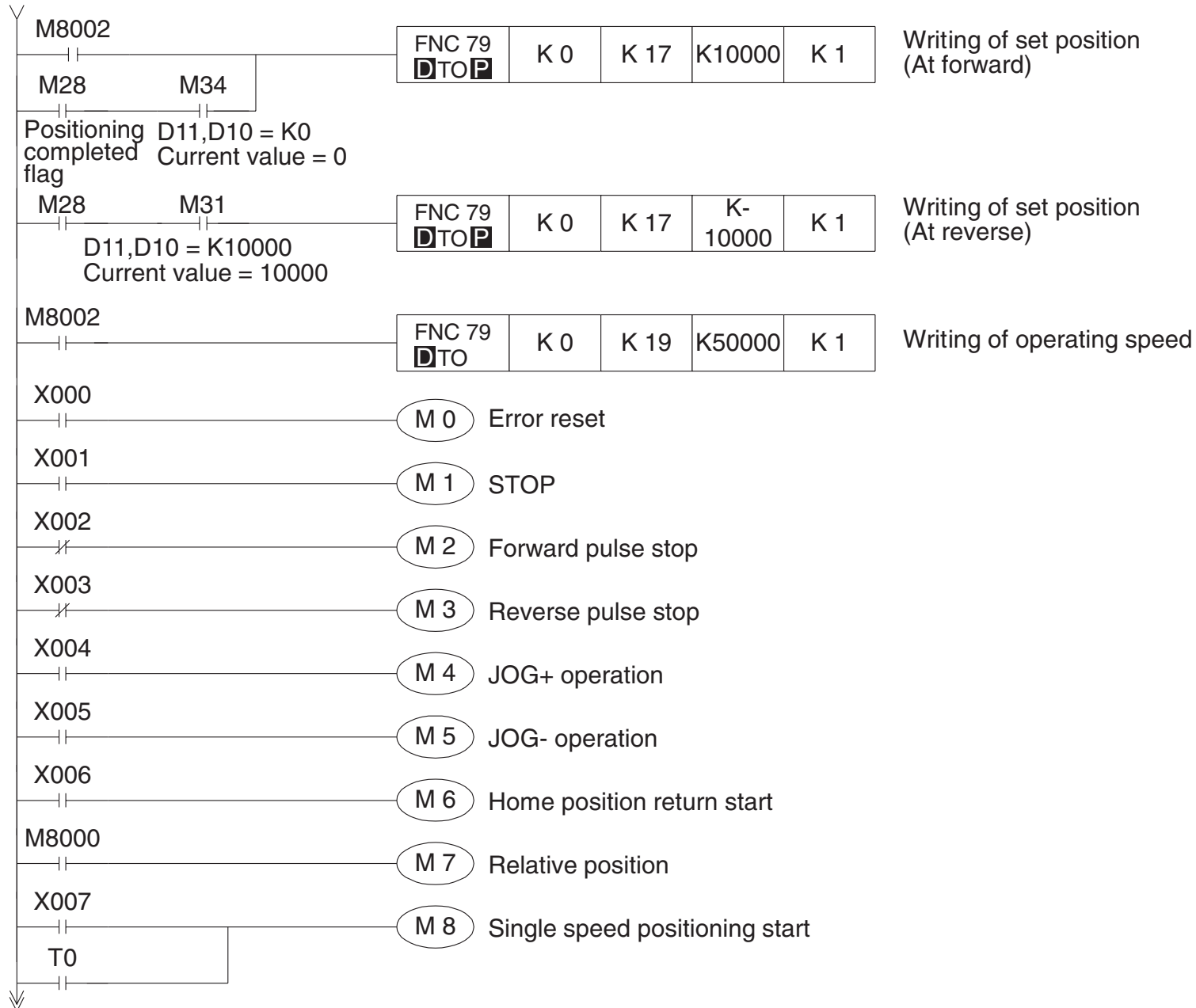

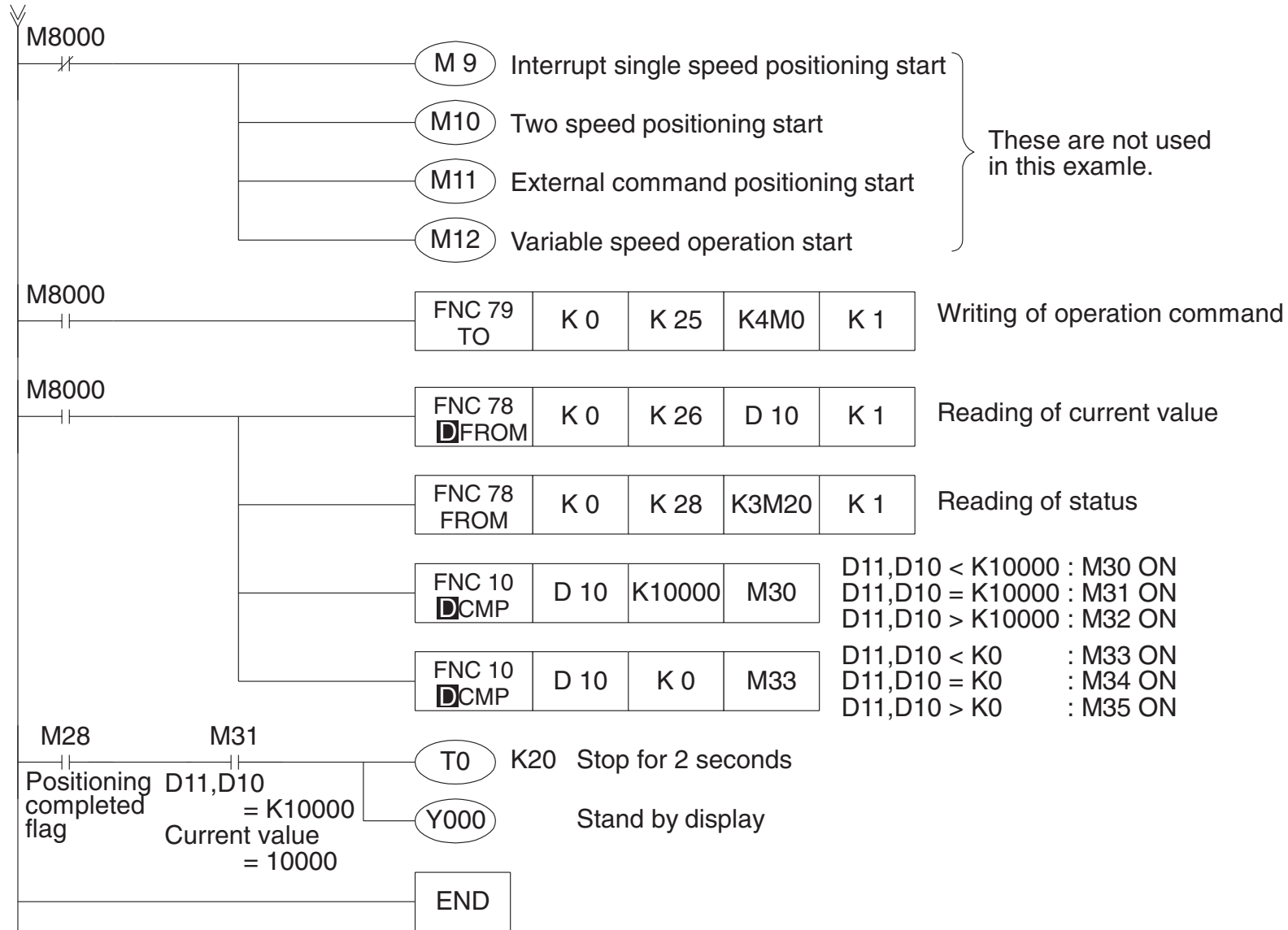



## 11. DIAGNOSTICS

### 11.1 Preliminary Checks and Error Indication

#### < To ensure correct operation >

- ① Make sure that the PGU I/O wiring and the extension cable connections are correct.  
Indicate clearly the special block No. on the panel face by adhering the labels offered as accessories.
- ② One PGU can occupy up to 8 points (including both inputs and outputs). Power of 5 V, 55 mA is required to be supplied from a main unit or an extension unit.  
Calculate and make sure that the total current required by all of the special blocks does not exceed the allowable current of the main unit or the extension unit used.
- ③ In any positioning operation, the specified data should be written preliminarily to the BFM #0 to #24, then the BFM #25 should give an appropriate command. Otherwise, the PGU does not function.  
Sometimes, however, data writing may not be required for some or all of the BFM #0 to #24 depending on the operation mode.  
Generally, the BFM #0 to #15 save the standard data, and the BFM #17 to #24 save the operation data. For the data to be set, see Section 6.6.

#### < Error indication >

- ① LED indication  
The PGU panel has the following LEDs:  
Power indication : The POWER LED is lighted when 5 V power is supplied from the PC.  
Input indication : When STOP, DOG or PG0 is received by the PGU, the corresponding LED is lighted respectively.  
Output indication : When FP, RP or CLR is output by the PGU, the corresponding LED is lighted respectively.  
Error indication : When an error occurs, the ERR LED flashes and the start command is not accepted.
- ② Error check  
Various errors can be checked by reading the contents of the BFM #29 to the PC.  
For the error descriptions, see Section 5.6.

#### < Note >

When performing the withstand voltage test of the FX-1PG, make sure to measure the voltage between the entire terminals and the ground terminal.

When performing the withstand voltage test of the FX<sub>2N</sub>-1PG, make sure to use the PC main unit also and to measure the voltage between the entire terminals of the FX<sub>2N</sub>-1PG and the ground terminal of the PC main unit.

# MEMO

- Under no circumstances will Mitsubishi Electric be liable responsible for any consequential damage that may arise as a result of the installation or use of this equipment.
- All examples and diagrams shown in this manual are intended only as an aid to understanding the text, not to guarantee operation. Mitsubishi Electric will accept no responsibility for actual use of the product based on these illustrative examples.
- Please contact a Mitsubishi Electric distributor for more information concerning applications in life critical situations or high reliability.

# USER'S MANUAL

FX-1PG/FX<sub>2</sub>N-1PG PULSE GENERATOR UNIT



HEAD OFFICE: MITSUBISHI DENKI BLDG MARUNOUCHI TOKYO 100-8310  
HIMEJI WORKS: 840, CHIYODA CHO, HIMEJI, JAPAN

|            |                 |
|------------|-----------------|
| MODEL      | FX2N/FX-1PG-U-E |
| MODEL CODE | 09R610          |

JY992D65301E  
(MEE)

Effective Apr. 2003  
Specifications are subject to change without notice.