



乐清市乐宇自动化电气有限公司

Yueqing Leyu Electric Automation Co., Ltd.

45W Single Output Industrial DIN Rail Power Supply

DR-45 series

Features:

Universal AC input/ full range

Protections: Short circuit/Over load/Over voltage/Over temperature

Cooling by free air convection

Can be installed on DIN rail TS-35/7.5 or 15

LED indicator for power on

100% full load burn-in test

Fixed switching frequency at 100KHz

1 year warranty

SPECIFICATIONS				
OUTPUT				
Model	DR-45-5	DR-45-12	DR-45-15	DR-45-24
DC Voltage	5V	12V	15V	24V
Rated Current	5A	3.5A	2.8A	2A
Current Range	0-5A	0-3.5A	0-2.8A	0-2A
Rated Power	25W	42W	42W	48W
Ripple & Noise	100mVp-p	200mVp-p	240mVp-p	480mVp-p
Voltage Adj. Range	4.75-5.5V	10.8-13.2V	13.5-16.5V	21.6-26.4V
Voltage Tolerance	±2%	±1%	±1%	±1%
Setup, Rise, Hold Up Time	800ms,100ms, 50ms/230VAC at full load			
INPUT				
Voltage Range	85~264VAC 47~63Hz; 120~370VDC			
AC Current	1.5A/115V 0.75A/230V			
Efficiency	72%	77%	77%	80%
Inrush Current	Cold start 30A/115V 60A/230V			
Leakage Current	<1mA/240VAC			
PROTECTION				
Over Load	105%~150%			
	Protection type: Constant current limiting, recovers automatically after fault condition is removed			
Over Voltage	115%~135%			
	Protection type: Shut off o/p voltage, clamping by zener diode			
Over Temp..	Tj 135°C typically (U1) Detect on heat sink of power transistor			
	Protection type: Shut down o/p voltage, re-power on to recover			



乐清市乐宇自动化电气有限公司
Yueqing Leyu Electric Automation Co., Ltd.

ENVIRONMENT	
Working Temp., Humidity	-10°C~+50°C; 20%~90%RH
Storage Temp., Humidity	-20°C~+85°C; 10%~95%RH
Temp. Coefficient	±0.03%/°C(0~50°C)
Vibration	10~500Hz, 2G 10min./1cycle, period for 60min, each along X, Y, Z axes
SAFETY	
Withstand Voltage	I/P-O/P: 3KVAC I/P-FG: 1.5KVAC O/P-FG: 0.5KVAC
Isolation Resistance	I/P-O/P, I/P-FG, O/P-FG: 100M Ohms / 500VDC
STANDARD	
Safety Standard	Design refer to UL508,TUV EN60950-1
EMC Standard	Design refer to EN55011,EN55022,EN61000-3-2,-3,EN61000-4-2,3,4,5,6,8,11,ENV50204,EN55024,EN61000-6-2
OTHERS	
Dimension	93*78*67mm (L*W*H)
Weight	0.31Kg
Packing	48pcs/16.1Kg/1.3CUFT
NOTE	
1.All parameters NOT specially mentioned are measured at 230VAC input, rated load and 25°C of ambient temperature. 2. Ripple & noise are measured at 20MHz of bandwidth by using a 12" twisted pair-wire terminated with a 0.1μ & 47μ parallel capacitor. 3.Tolerance: includes set up tolerance, line regulation and load regulation. 4.The power supply is considered a component which will be installed into a final equipment. The final equipment must be re-confirmed that it still meets EMC directives.	



®

乐清市乐宇自动化电气有限公司

Yueqing Leyu Electric Automation Co., Ltd.

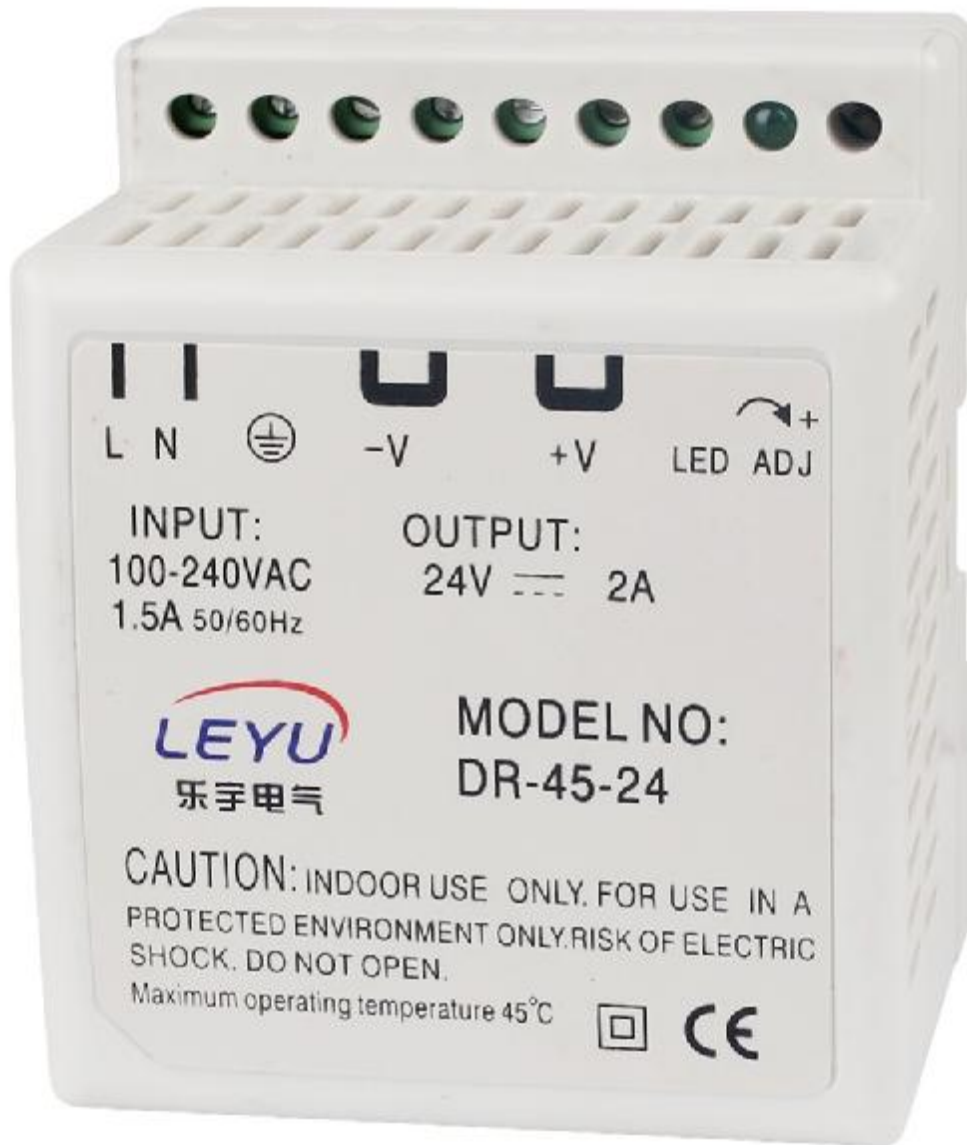

45W Single Output Industrial DIN Rail Power Supply

DR-45 Series

■ Outline and Dimension:

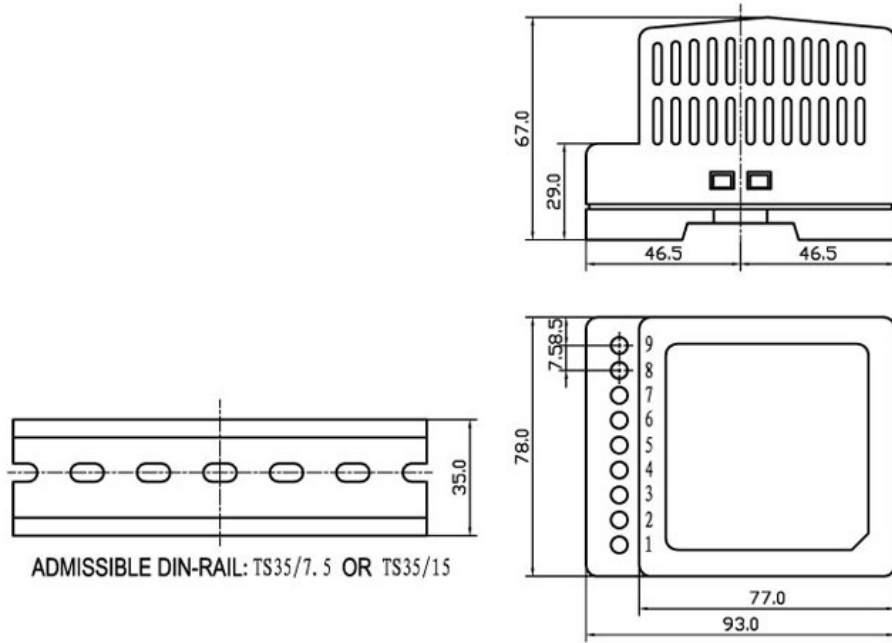

Terminal Pin No. Assignment:

Pin No.	Assignment	Pin No.	Assignment	Pin No.	Assignment
1	AC/L	4,5	DC OUTPUT -V	9	+V ADJ.
2	AC/N	6,7	DC OUTPUT +V		
3	PG 	8	LED		

■ Output Derating

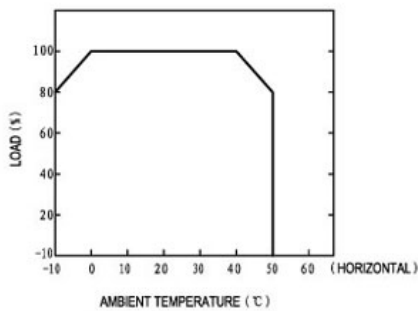

■ Static Characteristics (24V)

